

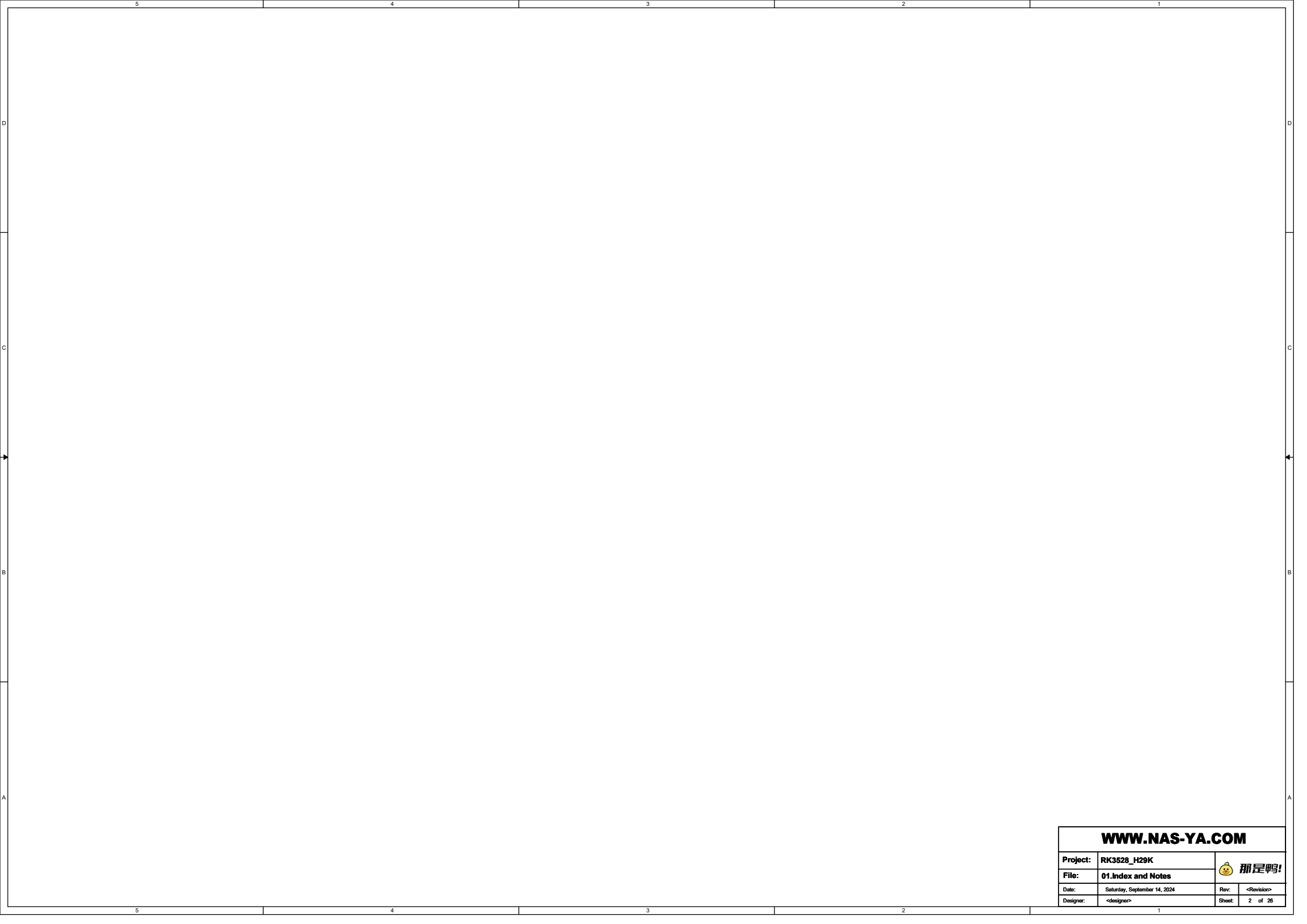

**WWW.NAS-YA.COM**

<b>Project:</b>	RK3528_H29K		
<b>File:</b>	00.Cover Page		
<b>Date:</b>	Saturday, September 14, 2024	<b>Rev:</b>	<Revision>
<b>Designer:</b>	<designer>	<b>Sheet:</b>	1 of 26



**WWW.NAS-YA.COM**

<b>Project:</b>	RK3528_H29K		
<b>File:</b>	01.Index and Notes	<b>Rev:</b>	<Revision>
<b>Date:</b>	Saturday, September 14, 2024	<b>Sheet:</b>	2 of 26
<b>Designer:</b>	<designer>		

# RK3528\_N (POWER)

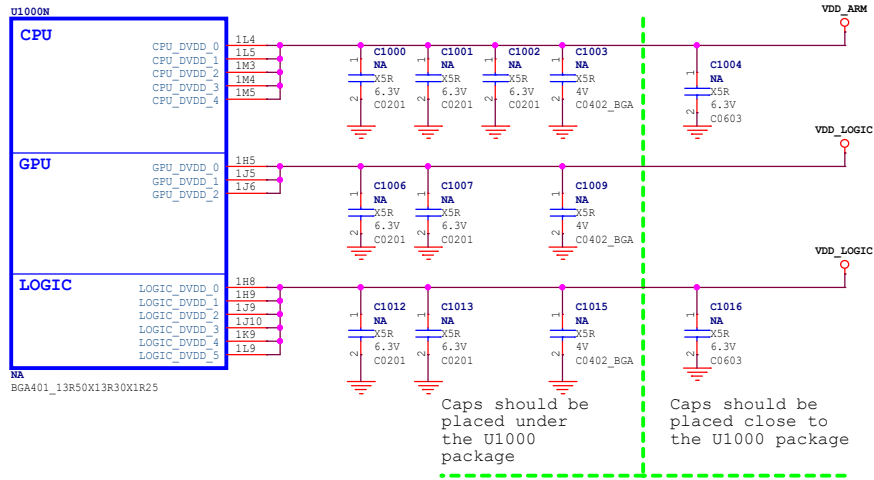

# RK3528\_O/P/Q (GND)

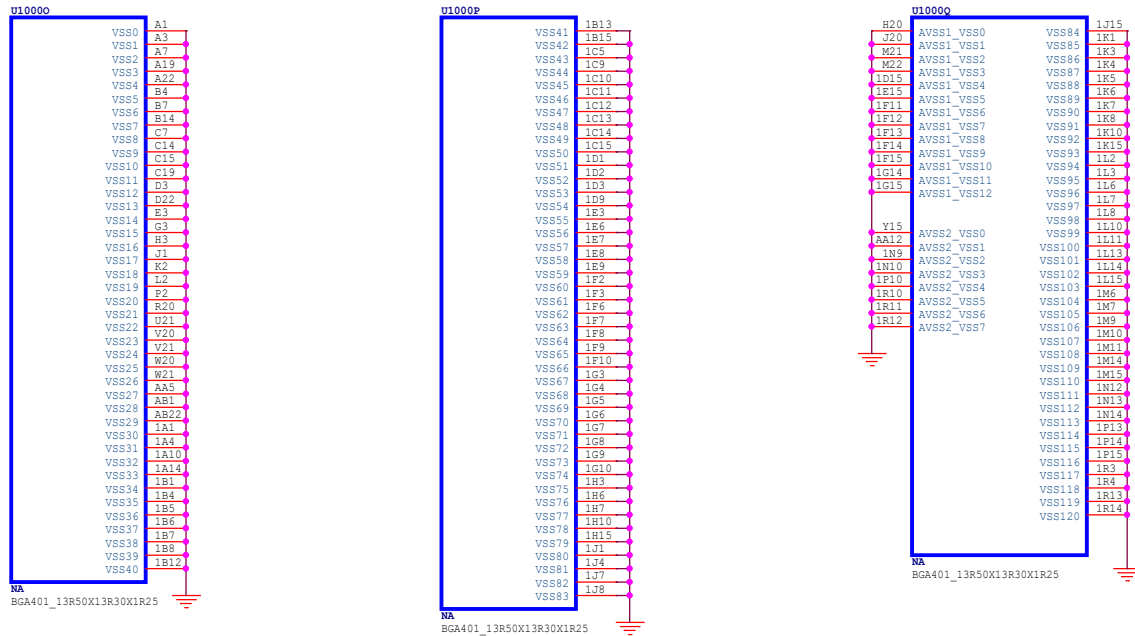

# RK3528\_B (OSC/PLL/PMUIO Domain)

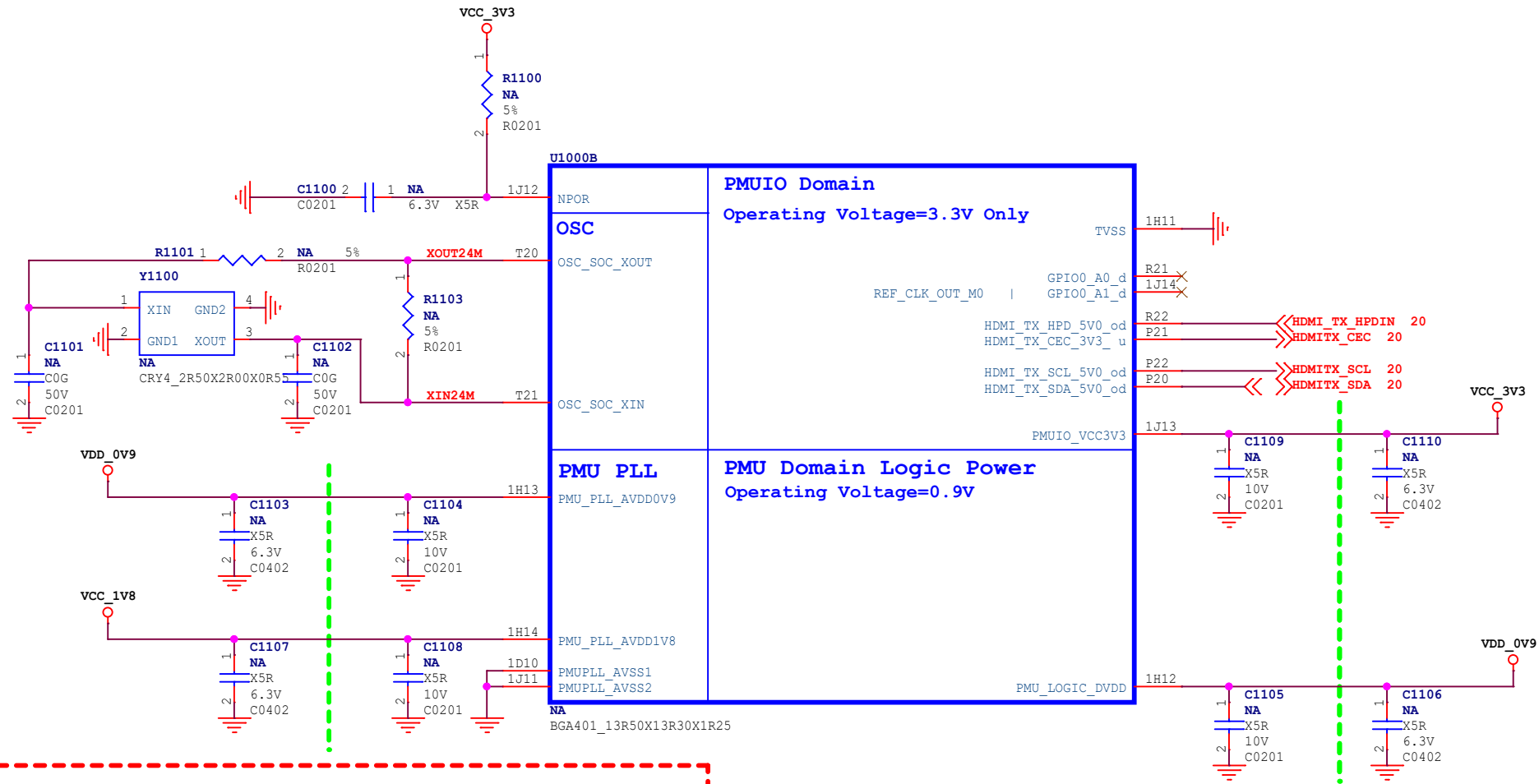

**Note:**  
Caps of between dashed green lines and U1000 should be placed under the U1000 package.  
Other caps should be placed close to the U1000 package

<b>WWW.NAS-YA.COM</b>			
<b>Project:</b>	RK3528_H29K	 <b>那是吗!</b>	
<b>File:</b>	03.RK3528 OSC/PLL/PMUIO		
<b>Date:</b>	Saturday, September 14, 2024	<b>Rev:</b>	<Revision>
<b>Designer:</b>	<designer>	<b>Sheet:</b>	4 of 26



# RK3528\_E (VCCIO1 Domain)

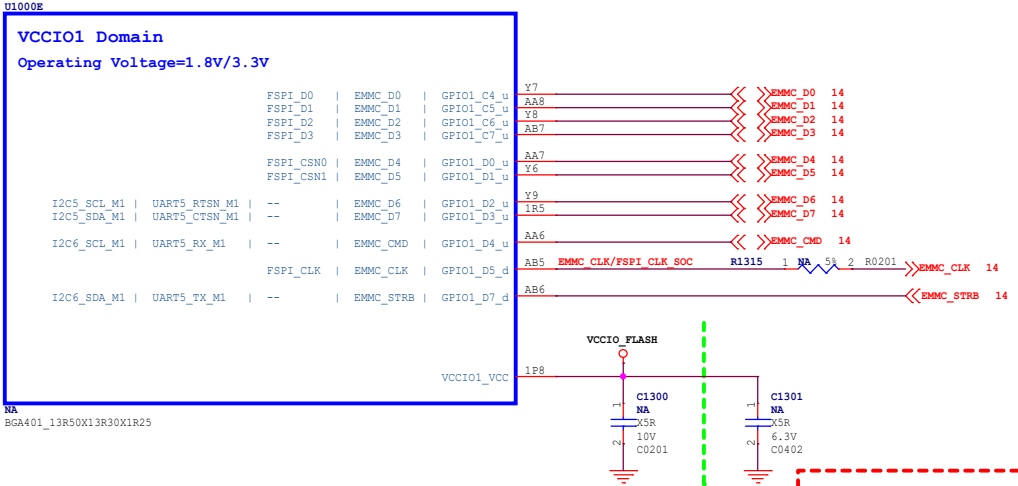

FSPI (Flexible Serial Peripheral Interface) is only used to connect SPI Flash/Memory devices. Do not use for connecting to other SPI devices.

Default DiscretePower solution, power by VCC\_1V8  
 PMIC solution, power by VCC1V8\_EMMC, only 1.8V

**Note:**  
 Caps of between dashed green lines and U1000 should be placed under the U1000 package.  
 Other caps should be placed close to the U1000 package

# RK3528\_F (VCCIO2 Domain)

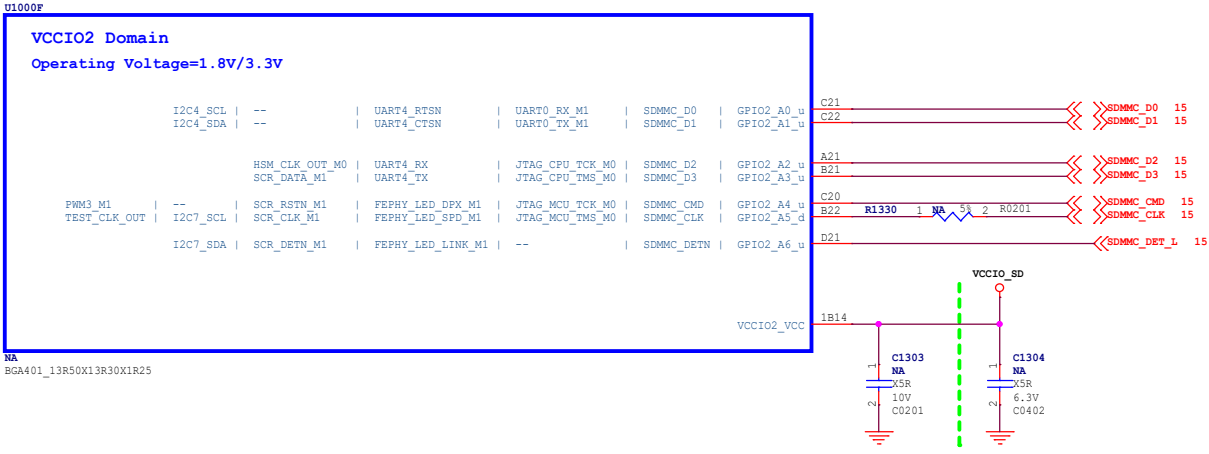

**Note:**  
 Caps of between dashed green lines and U1000 should be placed under the U1000 package.  
 Other caps should be placed close to the U1000 package

WWW.NAS-YA.COM

Project:	RK3528_H29K	
File:	05.RK3528 FLASH/SD Controller	
Date:	Saturday, September 14, 2024	Rev: <Revision>
Designer:	<designer>	Sheet: 6 of 26



# RK3528\_C (Saradc/OTP)

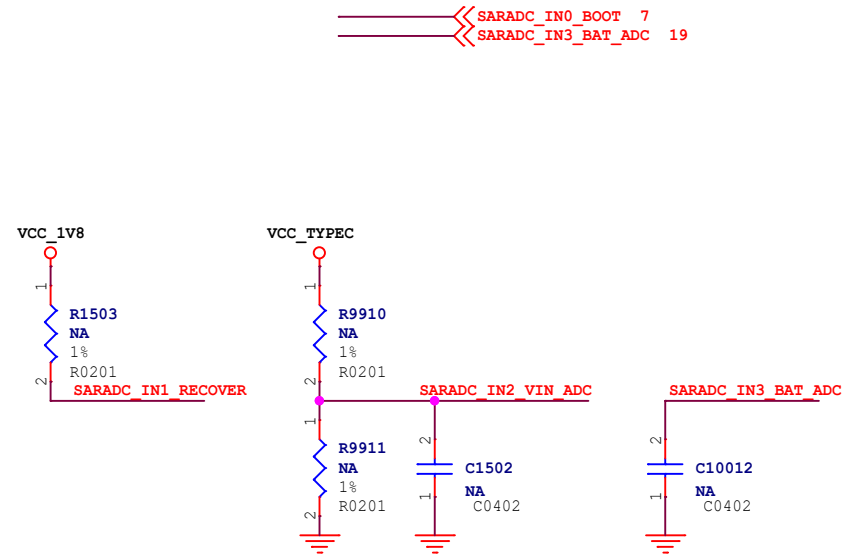
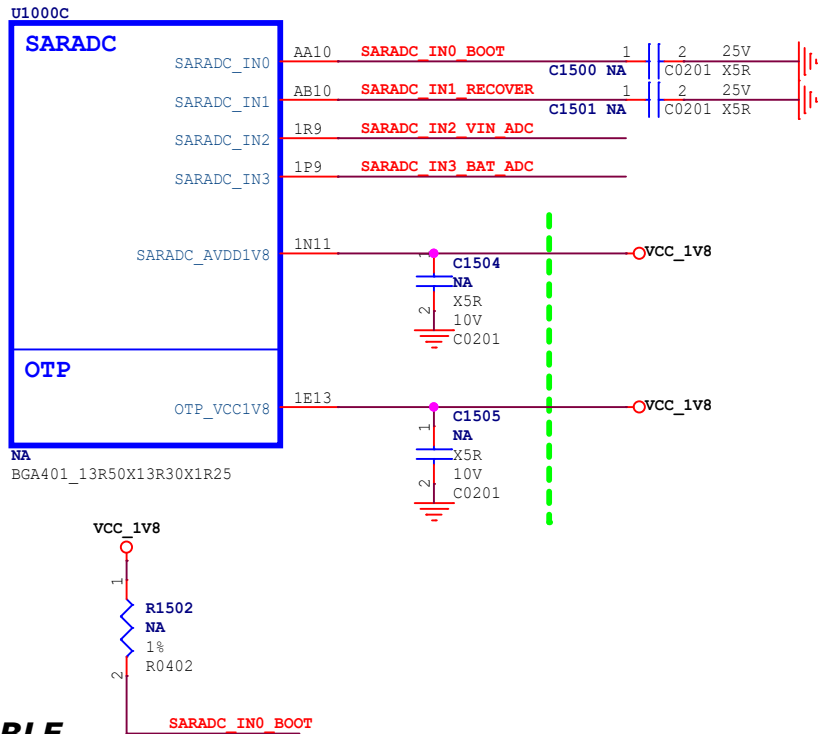

## TABLE

Item	Rup	Rdown	ADC	BOOT MODE
LEVEL1	DNP	100K	0	USB (Maskrom mode)
LEVEL2	100K	12K	114	
LEVEL3	100K	27K	228	FSPI--USB
LEVEL4	100K	51K	342	
LEVEL5	100K	82K	456	
LEVEL6	100K	120K	570	EMMC--USB
LEVEL7	100K	200K	683	EMMC--SD Card--USB
LEVEL8	100K	330K	796	SD Card--USB
LEVEL9	100K	820K	910	
LEVEL10	100K	DNP	1023	FSPI--EMMC--SD Card--USB

**WWW.NAS-YA.COM**

<b>Project:</b>	RK3528_H29K	🧡 那是吗!
<b>File:</b>	07.RK3528 SARADC/OTP	
<b>Date:</b>	Saturday, September 14, 2024	<b>Rev:</b> <Revision>
<b>Designer:</b>	<designer>	<b>Sheet:</b> 8 of 26



# RK3528\_L (HDMI PHY)

U1000L

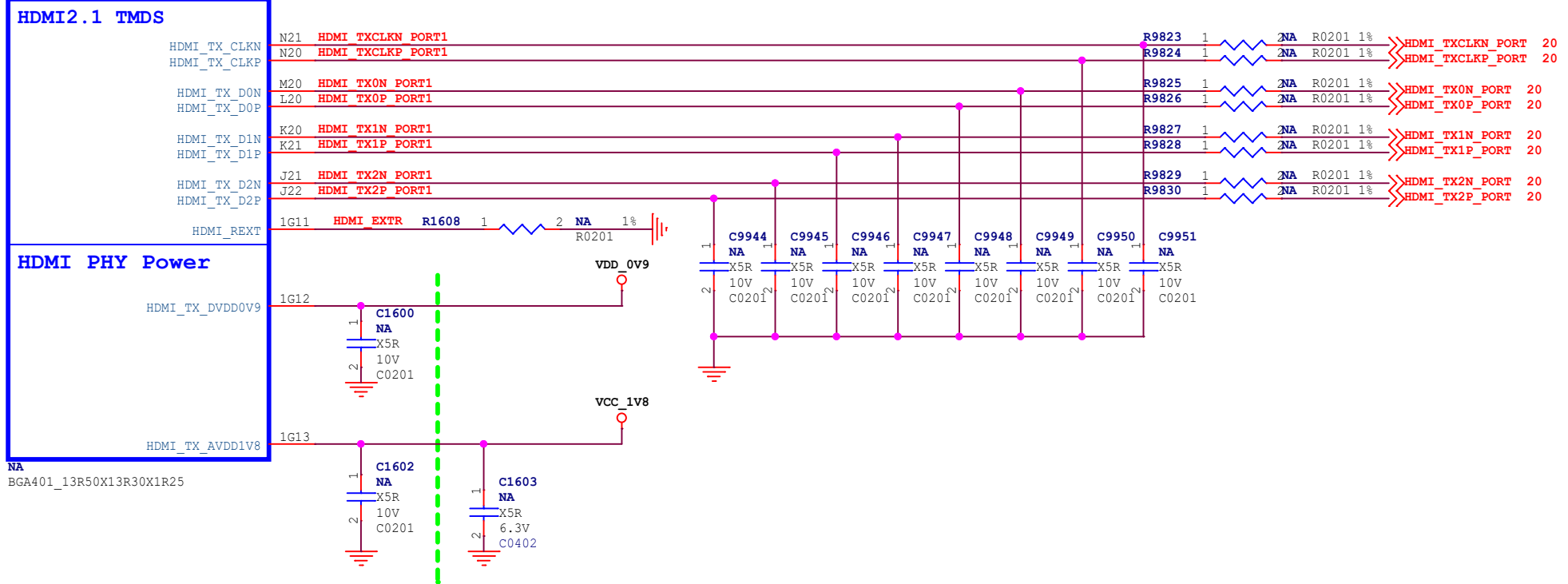

NA  
BGA401\_13R50X13R30X1R25

**Note:**  
Caps of between dashed green lines and U1000 should be placed under the U1000 package.  
Other caps should be placed close to the U1000 package

<b>WWW.NAS-YA.COM</b>			
<b>Project:</b>	RK3528_H29K	🧡 那是吗!	
<b>File:</b>	08.RK3528 HDMI Interface		
<b>Date:</b>	Saturday, September 14, 2024	<b>Rev:</b>	<Revision>
<b>Designer:</b>	<designer>	<b>Sheet:</b>	9 of 26

# RK3528\_M (Acodect/VDAC)

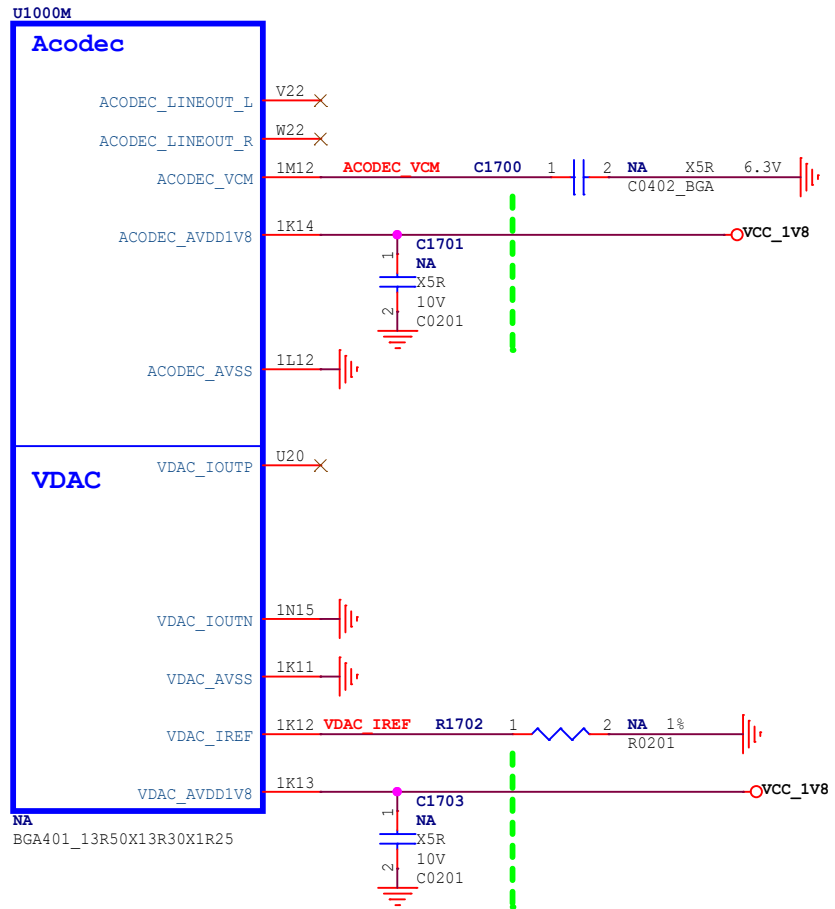

**Note:**

Caps of between dashed green lines and U1000 should be placed under the U1000 package.  
Other caps should be placed close to the U1000 package

**WWW.NAS-YA.COM**

<b>Project:</b>	RK3528_H29K	🧸 那是鸭!
<b>File:</b>	09.RK3528 AV OUT	
<b>Date:</b>	Saturday, September 14, 2024	Rev: <Revision>
<b>Designer:</b>	<designer>	Sheet: 10 of 26

# RK3528\_K (Embed FEPHY)

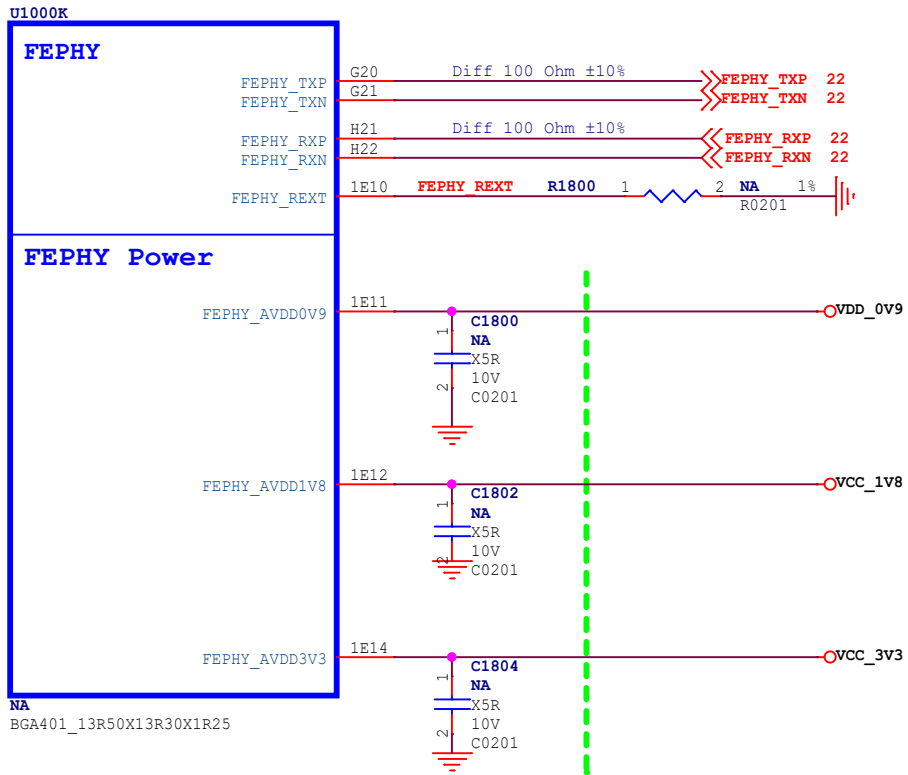

**Note:**

Caps of between dashed green lines and U1000 should be placed under the U1000 package.  
 Other caps should be placed close to the U1000 package

**WWW.NAS-YA.COM**

<b>Project:</b>	RK3528_H29K	 那是吗!
<b>File:</b>	10.RK3528 Embed FEPHY	
<b>Date:</b>	Saturday, September 14, 2024	Rev: <Revision>
<b>Designer:</b>	<designer>	Sheet: 11 of 26



DDR

**WWW.NAS-YA.COM**

<b>Project:</b>	RK3528_H28K		那 是 哪 呀
<b>File:</b>	12.DRAM_LPDDR4X_1X32BH		
<b>Date:</b>	Saturday, September 14, 2024	<b>Rev:</b>	<None>
<b>Designer:</b>	<signature>	<b>Sheet:</b>	13 of 28

5

4

3

2

1

D

D

C

C

**EMMC**

B

B

A

A

**WWW.NAS-YA.COM**

<b>Project:</b>	RK3528_H29K	 <b>那是吗!</b>	
<b>File:</b>	13.Flash-eMMC		
<b>Date:</b>	Saturday, September 14, 2024	<b>Rev:</b>	<Revision>
<b>Designer:</b>	<designer>	<b>Sheet:</b>	14 of 26

5

4

3

2

1

# TF Card

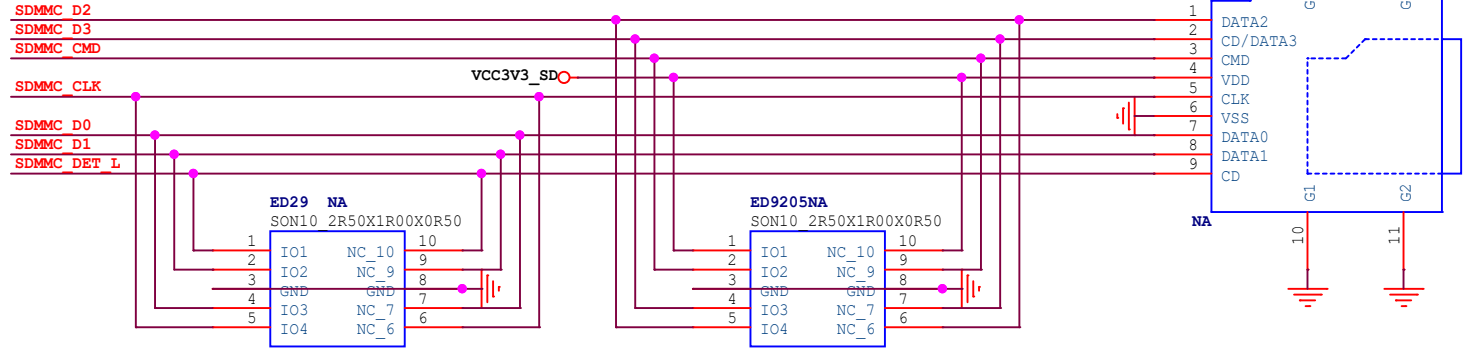
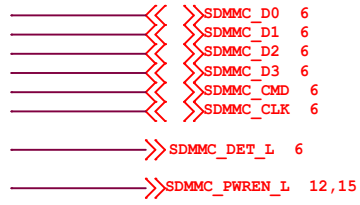

# VCCIO\_SD

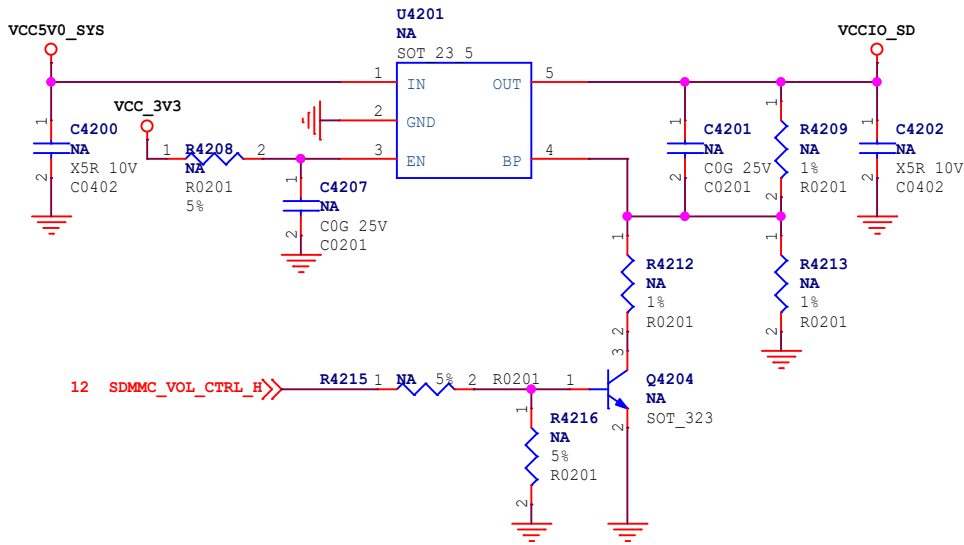

SDIO2.0 SDMMC0\_VOL\_CTRL=H VCCIO\_SD=3.34V(Default)  
 SDIO3.0 SDMMC0\_VOL\_CTRL=L VCCIO\_SD=1.816V

# VCC3V3\_SD

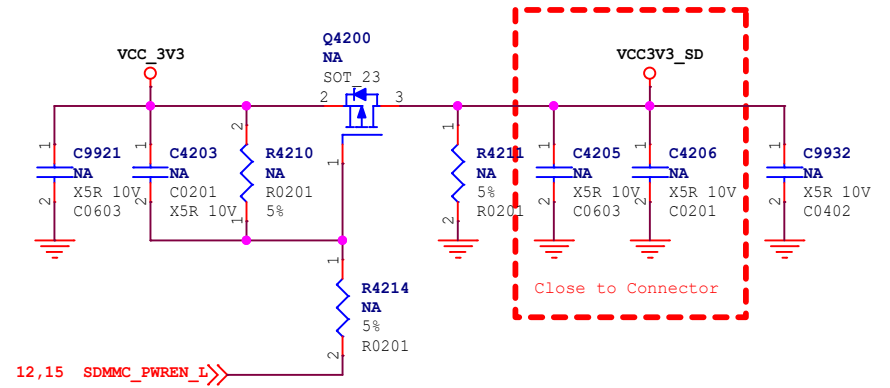

SDMMC\_PWREN=L VCC\_SD=3.3V(Default)  
 SDMMC\_PWREN=H VCC\_SD=0V

**WWW.NAS-YA.COM**

<b>Project:</b>	RK3528_H29K	
<b>File:</b>	14.Flash-Micro-SD Card	
<b>Date:</b>	Saturday, September 14, 2024	<b>Rev:</b> <Revision>
<b>Designer:</b>	<designer>	<b>Sheet:</b> 15 of 26

电源

WWW.NAS-YA.COM

Project:	RK3528_H28K	
File:	15.Power-DiscretePower	
Date:	Saturday, September 14, 2024	Rev: <None>
Designer:	<None>	Sheet: 16 of 28



# 电源

**WWW.NAS-YA.COM**

Project:	RK3528_H29K	 <b>那是吗!</b>	
File:	16.Power-DCIN		
Date:	Saturday, September 14, 2024	Rev:	<Revision>
Designer:	<designer>	Sheet:	17 of 26

# 电源

**WWW.NAS-YA.COM**

Project:	RK3528_H29K	 那是吗!
File:	17.Power_Charge	
Date:	Saturday, September 14, 2024	Rev: <Revision>
Designer:	<designer>	Sheet: 18 of 26

# USB2.0 HOST1

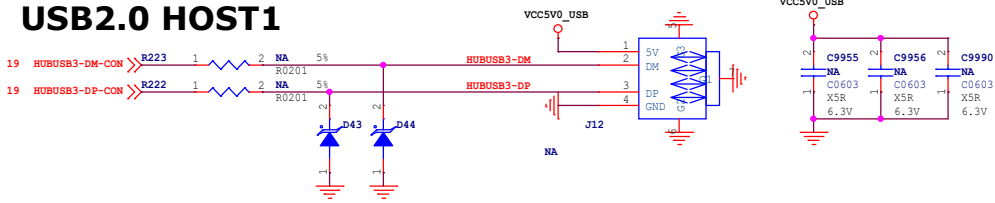

# 5V USB

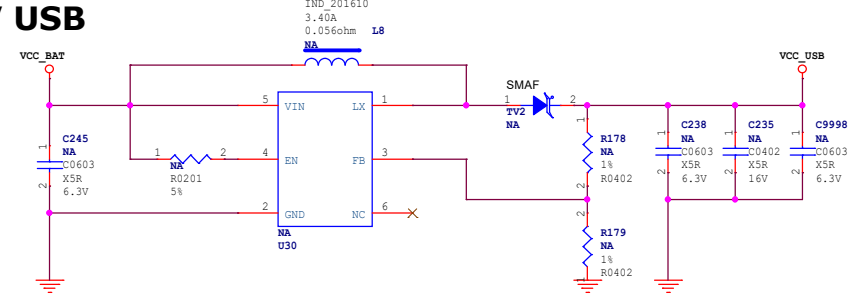

# USB2.0 HOST2

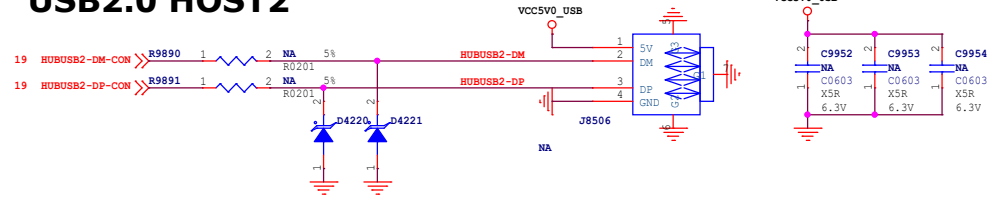

# USB2.0 HUB

# USB2.0 other

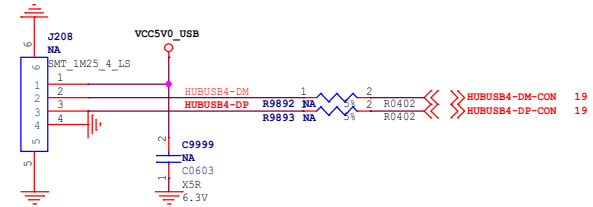

WWW.NAS-YA.COM

Project:	RK3528_H29K	
File:	18.USB_HUB_A	
Date:	Saturday, September 14, 2024	Rev: <Revision>
Designer:	<designer>	Sheet: 19 of 26

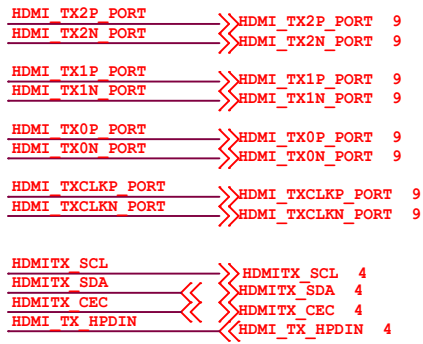

### HDMI TX DDC

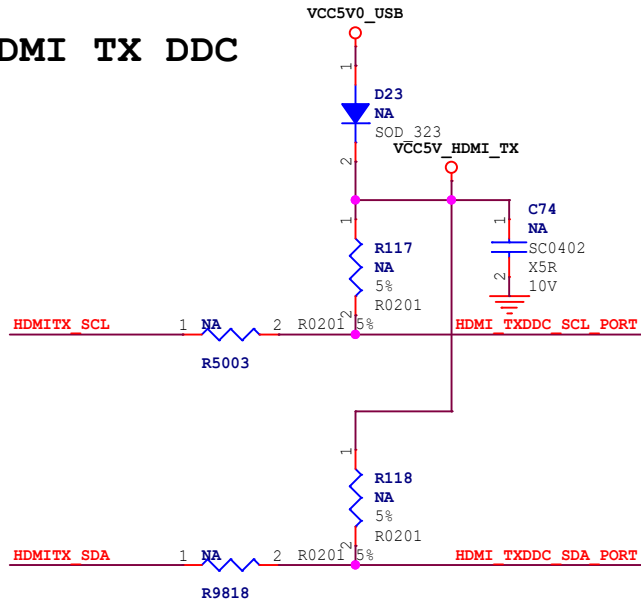

### HDMI TX CEC



### HDMI TX HPD

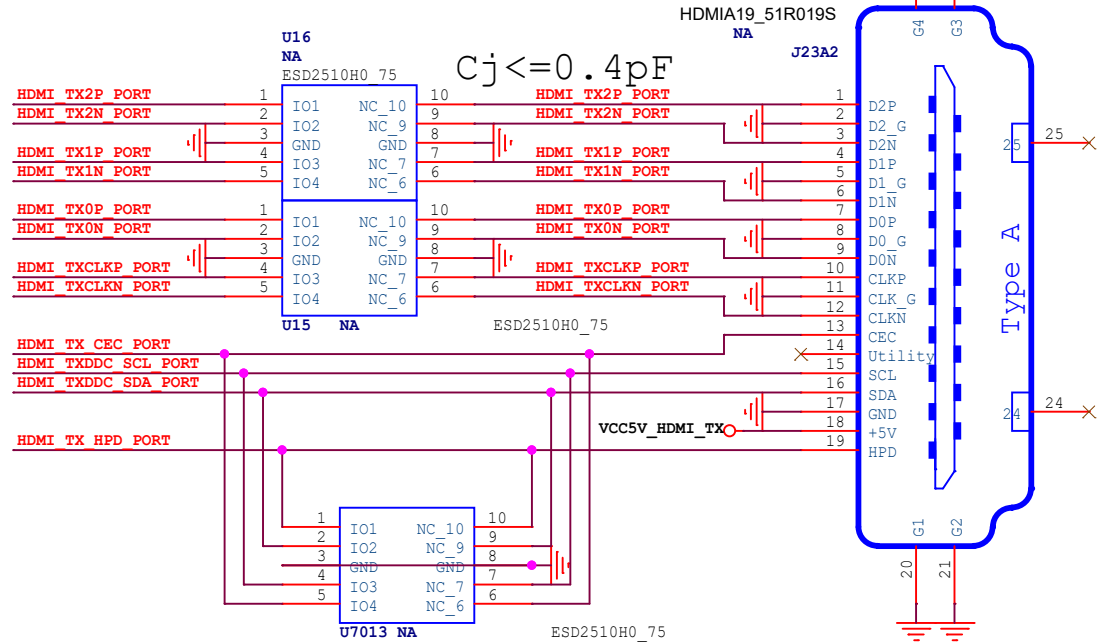
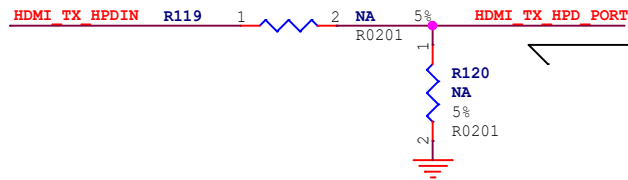

WWW.NAS-YA.COM

Project:	RK3528_H29K	那是吗!
File:	19.VO-HDMI2.0 TX	
Date:	Saturday, September 14, 2024	Rev: <Revision>
Designer:	<designer>	Sheet: 20 of 26





# KEY

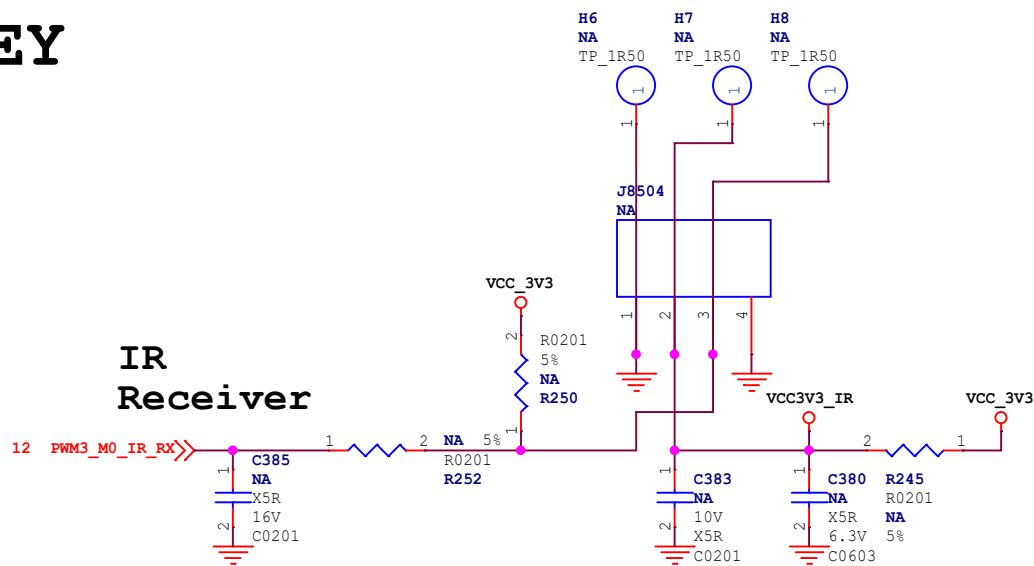

## IR Receiver

# 屏幕

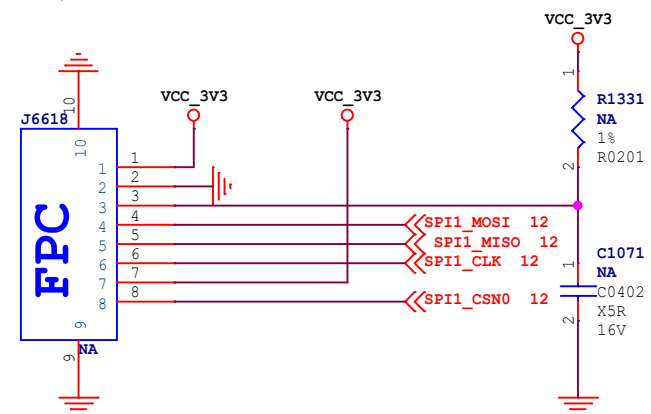

## Encryption

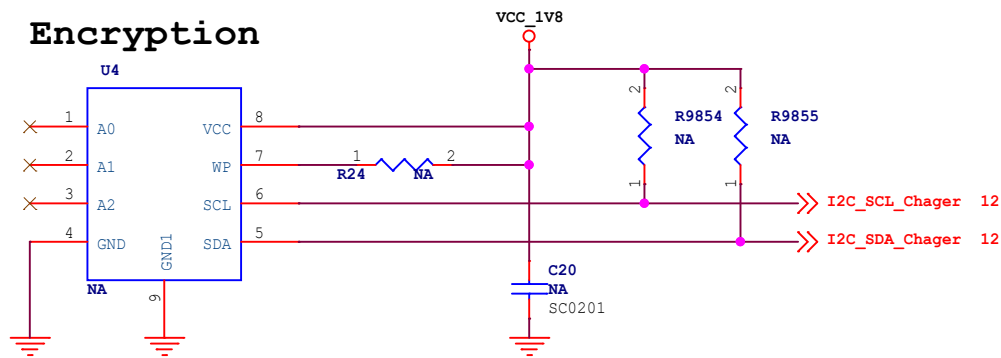

1号灯

2号灯

3号灯

3号灯

## 电源灯

## 工作灯

## 充电灯

## 充电灯

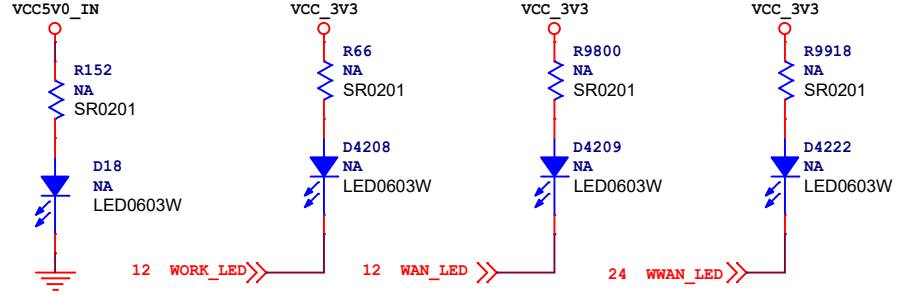

**WWW.NAS-YA.COM**

Project:	RK3528_H29K	
File:	22.Key/HW ID/LED	
Date:	Saturday, September 14, 2024	Rev: <Revision>
Designer:	<designer>	Sheet: 23 of 26

# M2\_NGFF-4G/5G

FM650-CN-03-00

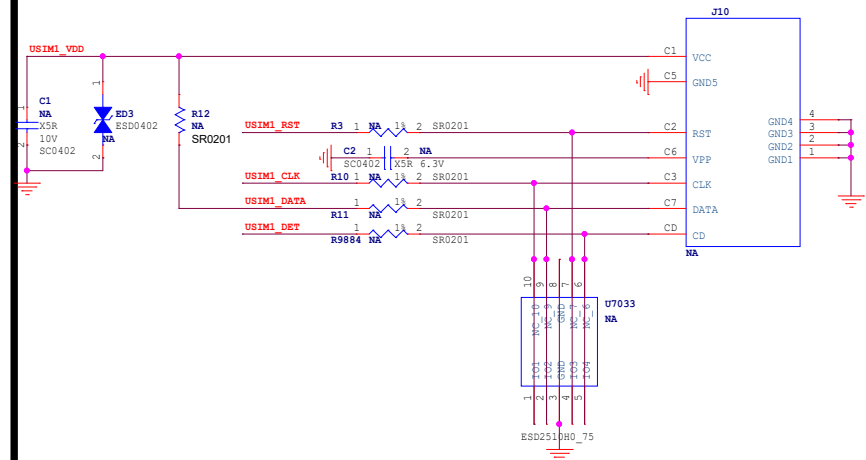
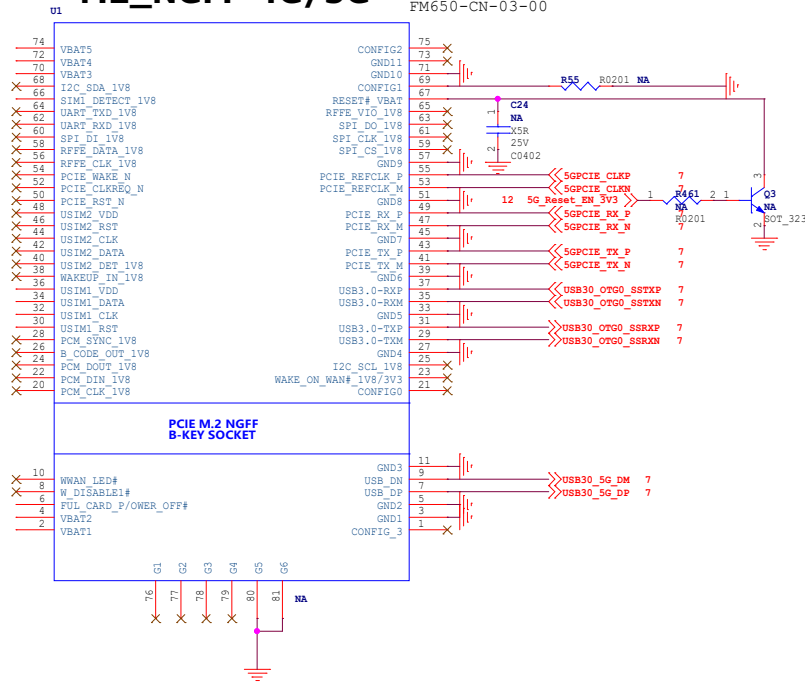

WWW.NAS-YA.COM

Project:	RK3528_H28K	那是吗!
File:	23.4G/5G-MODULE	
Date:	Saturday, September 14, 2024	Rev: <Revision>
Designer:	<designer>	Sheet: 24 of 26



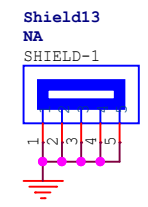
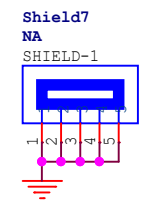
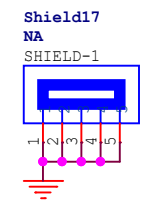
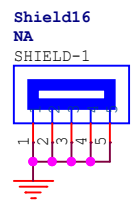
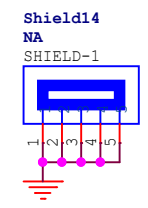
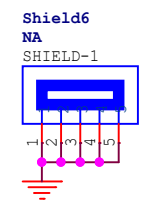
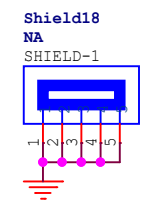
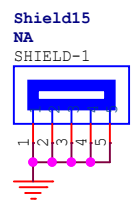
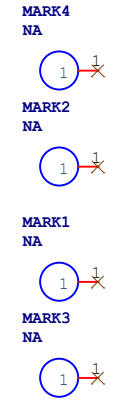
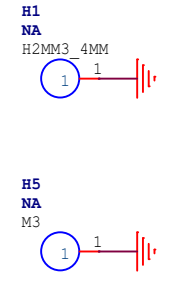
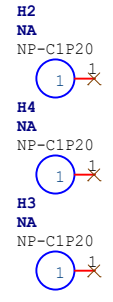

<b>WWW.NAS-YA.COM</b>			
<b>Project:</b>	RK3528_H29K	 <b>那是鸭!</b>	
<b>File:</b>	24.Mark/Hole		
<b>Date:</b>	Saturday, September 14, 2024	<b>Rev:</b>	<Revision>
<b>Designer:</b>	<designer>	<b>Sheet:</b>	25 of 26

PCIE TO RJ45

H29K忽略PCIE网卡  
这部分预留的是H28-MAX

