

# Reference Schematics For RK3528

## RK3528\_BOX\_REF\_SCH\_V10

### Main Functions Introduction

- 1) Power: DiscretePower:BUCK+LDO or PMIC RK805-6
- 2) RAM: DDR3 4x16bit  
DDR4 2x16Bit  
DDR4 4x16Bit  
LPDDR3 1x32bit  
LPDDR4/LPDDR4X 1x32bit
- 3) ROM: eMMC5.1 or FSPI Flash
- 4) Support: Micro SD Card3.0
- 5) Support: 1 x USB3.0 OTG + 1 x USB2.0 HOST
- 6) Support: 1 x HDMI2.0 TX
- 7) Support: 1 x AV OUT
- 8) Support: SDIO WiFi5 + UART/PCM BT  
PCIE WIFI5 + UART/PCM BT
- 9) Support: 1 x Ethernet(Embed PHY) + 1x Ethernet(RGMII or RMII)
- 10) Support: Optical S/PDIF TX
- 11) Support: IR Receiver
- 12) Support: Audio-MicArray 2xI2S-DMIC or 4xPDM-DMIC
- 13) Support: RECOVER/RESET/SARADC\_BOOT\_KEY,HW\_ID
- 14) Support: 1 x PCIE2.0 Slot
- 15) Support: Debug UART

**WWW.NAS-YA.COM**

<b>Project:</b>	RK3528_H29K	 那是吗!
<b>File:</b>	00.Cover Page	
<b>Date:</b>	Thursday, November 14, 2024	<b>Rev:</b> <Revision>
<b>Designer:</b>	<designer>	<b>Sheet:</b> 1 of 25

# Table of Content

Page 1	00.Cover Page
Page 2	01.Index and Notes
Page 3	02.Revision History
Page 4	03.Block Diagram
Page 5	04.Power Tree-DiscretePower
Page 6	04.Power Tree-PMIC RK805-6
Page 7	05.Power Sequence-DiscretePower
Page 8	05.Power Sequence-PMIC RK805-6
Page 9	06.UART Map
Page 10	07.I2C Bus Map
Page 11	08.USB3/PCIE Fun Map
Page 12	10.RK3528 Power/GND
Page 13	11.RK3528 OSC/PLL/PMUIO
Page 14	12.RK3528 DDR Controller
Page 15	13.RK3528 FLASH/SD Controller
Page 16	14.RK3528 USB/PCIE Controller
Page 17	15.RK3528 SARADC/OTP
Page 18	16.RK3528 HDMI Interface
Page 19	17.RK3528 AV OUT
Page 20	18.RK3528 Embed FEPHY
Page 21	19.RK3528_1.8V/3.3V GPIO
Page 22	20.Power-DCIN
Page 23	21.Power-DiscretePower
Page 24	22.Power-PMIC-RK805-6(OPTION)
Page 25	25.USB2/USB3 Port
Page 26	30.DRAM DDR3 4x16bit_96P
Page 27	30.DRAM-DDR4_2x16Bit_96P
Page 28	30.DRAM-DDR4_4x16Bit_96P
Page 29	30.DRAM-LPDDR3_1X32bit_178P
Page 30	30.DRAM-LPDDR4_1X32bit_200P
Page 31	30.DRAM-LPDDR4X_1X32bit_200P
Page 32	40.Flash-eMMC
Page 33	42.Flash-Micro-SD Card
Page 34	43.Flash-SPI FLASH(OPTION)
Page 35	50.VO-HDMI TX
Page 36	51.VO-AV Interface
Page 37	61.WIF/BT-SDIO_2T2R_AP6275S
Page 38	62.WIF/BT-SDIO_2T2R_RTL8822CS
Page 39	63.WIFI6/BT-PCIe_2T2R_AP6275P
Page 40	65.10/100M-Embed PHY
Page 41	66.Ethernet-FEPHY_RMII
Page 42	67.Ethernet-GEPHY_RGMII
Page 43	76.Audio-Headphone/MICIN
Page 44	77.Audio-MicArray(2xI2S-DMIC)
Page 45	78.Audio-MicArray(4xPDM-DMIC)
Page 46	80.PCIE-PCIE2.0_Slot(OPTION)
Page 47	90.Spdif TX/IR_RX
Page 48	92.Key/HW ID/LED
Page 49	93.Debug UART
Page 50	99.Mark/Hole/Heatsink
Page 51	
Page 52	
Page 53	

## Generate Bill of Materials

### Header:

Item\Part\Description\PCB Footprint\Reference\Quantity\Option

### Combined property string:

{Item}\t{Value}\t{Description}\t{PCB Footprint}\t{Reference}\t{Quantity}\t{Option}

Description

Note

Option

## Notes

### NOTE 1:

#### Component parameter description

1. DNP stands for component not mounted temporarily
2. If Value or option is DNP, which means the area is reserved without being mounted

### NOTE 2:

Please use our recommended components to avoid too many changes.  
For more informations about the second source,please refer to our AVL.

WWW.NAS-YA.COM

Project:	RK3528_H29K		
File:	01.Index and Notes		
Date:	Thursday, November 14, 2024	Rev:	<Revision>
Designer:	<designer>	Sheet:	2 of 25

# RK3528\_N (POWER)

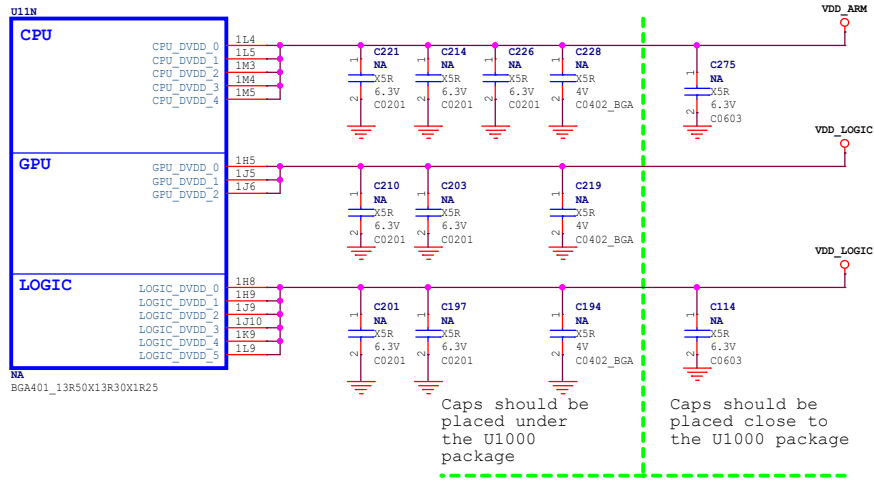

Caps should be placed under the U1000 package

Caps should be placed close to the U1000 package

**Note:**  
Caps of between dashed green lines and U1000 should be placed under the U1000 package.  
Other caps should be placed close to the U1000 package

# RK3528\_O/P/Q (GND)

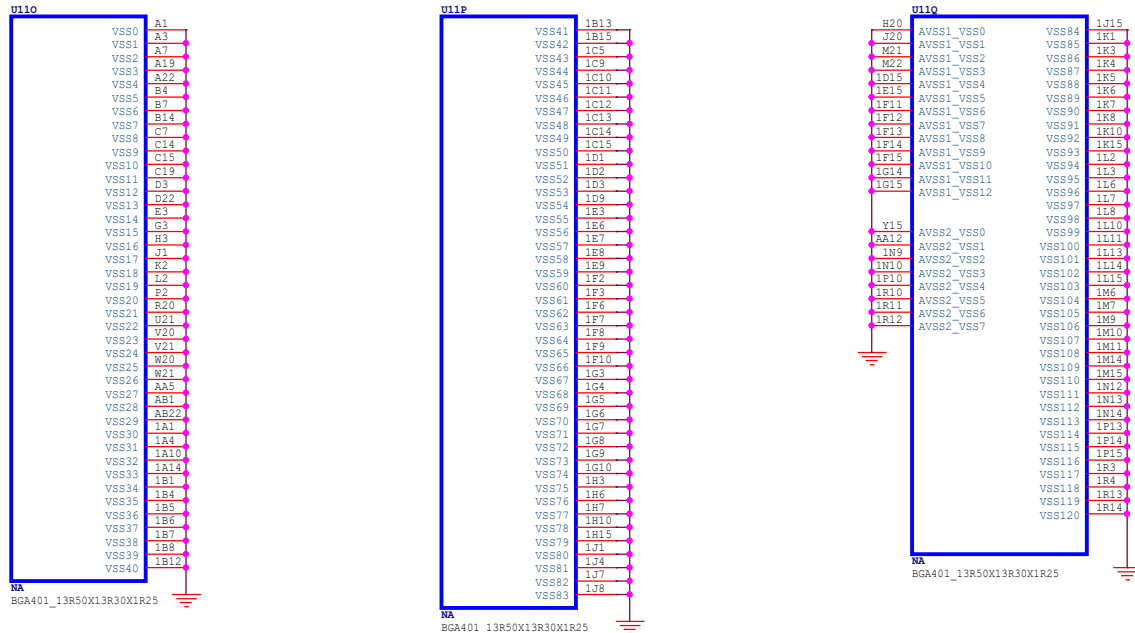

# RK3528\_B (OSC/PLL/PMUIO Domain)

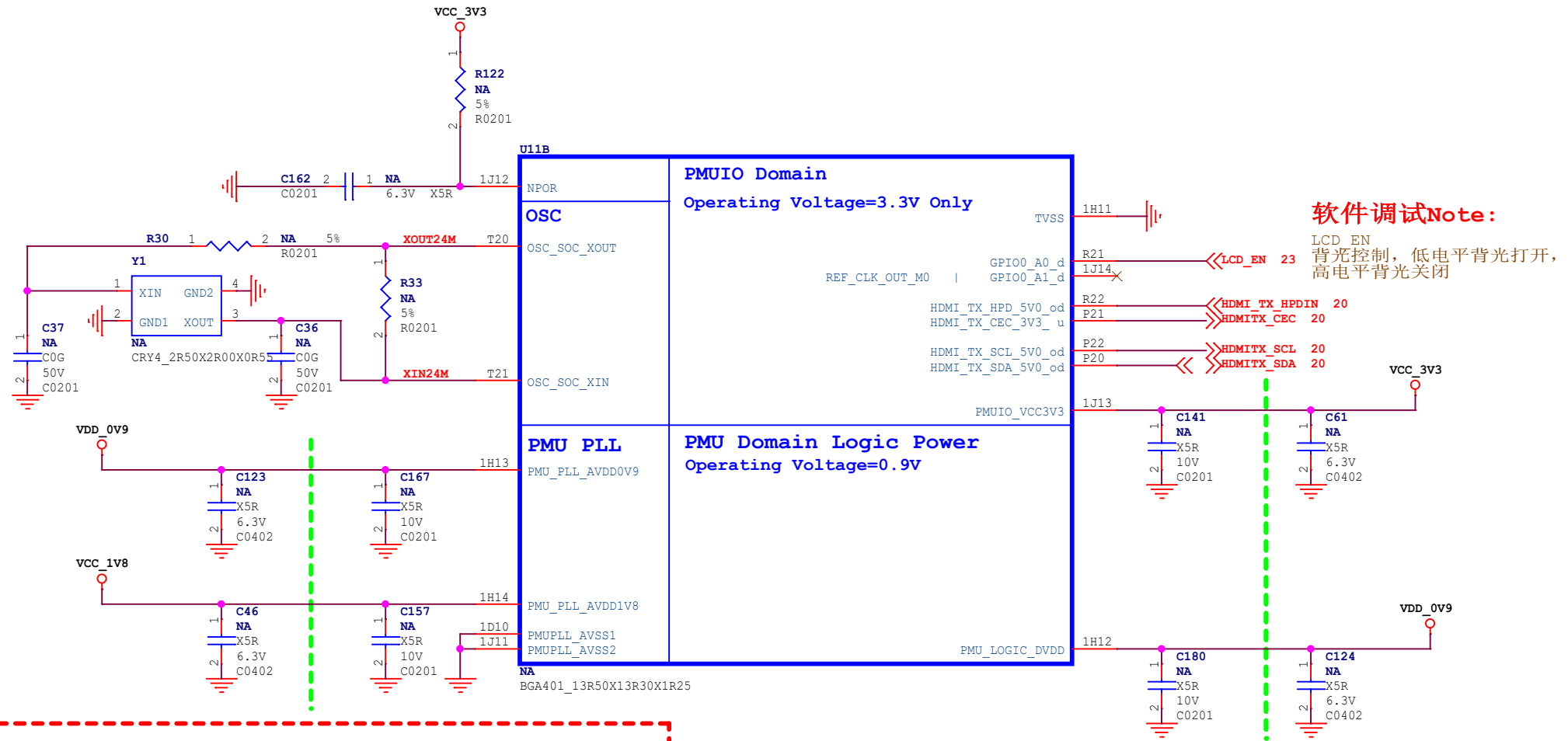

**Note:**  
Caps of between dashed green lines and U1000 should be placed under the U1000 package.  
Other caps should be placed close to the U1000 package

<b>WWW.NAS-YA.COM</b>			
<b>Project:</b>	RK3528_H29K	🧡 那是吗!	
<b>File:</b>	03.RK3528 OSC/PLL/PMUIO		
<b>Date:</b>	Thursday, November 14, 2024	<b>Rev:</b>	<Revision>
<b>Designer:</b>	<designer>	<b>Sheet:</b>	4 of 25



# RK3528\_E (VCCIO1 Domain)

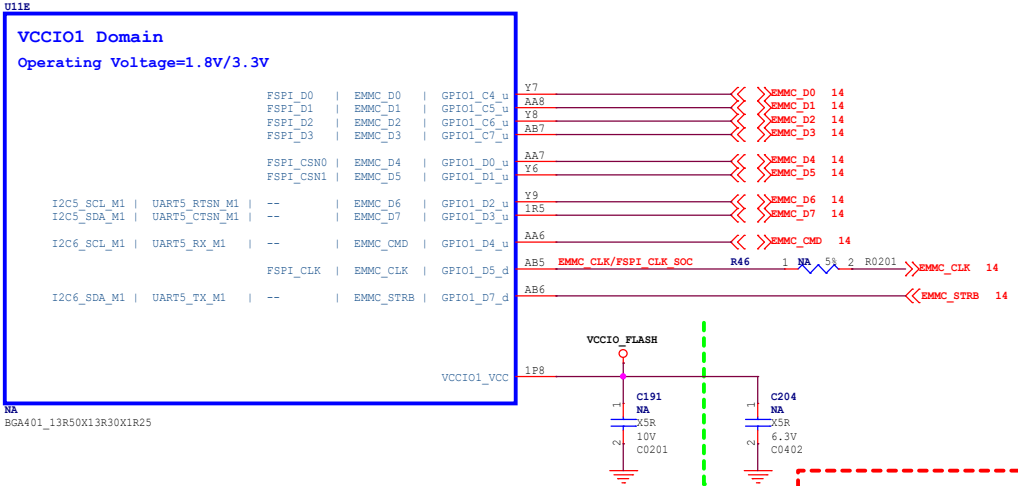

FSPI(Flexible Serial Peripheral Interface) is only used to connect SPI Flash/Memory devices.  
Do not use for connecting to other SPI devices

Default  
DiscretePower solution, power by VCC\_1V8  
PMIC solution, power by VCC1V8\_EMMC, only 1.8V

**Note:**  
Caps of between dashed green lines and U1000 should be placed under the U1000 package.  
Other caps should be placed close to the U1000 package

# RK3528\_F (VCCIO2 Domain)

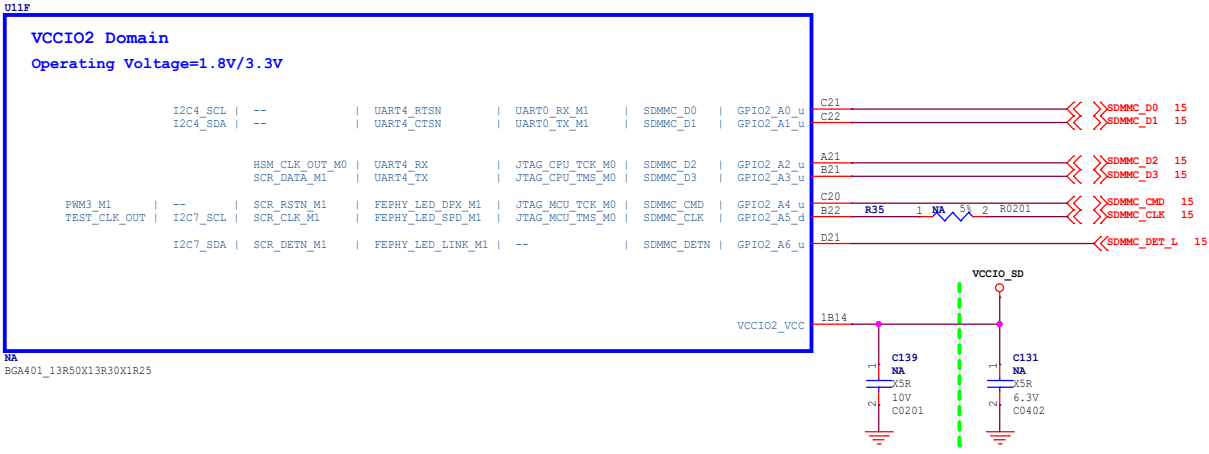

**Note:**  
Caps of between dashed green lines and U1000 should be placed under the U1000 package.  
Other caps should be placed close to the U1000 package

WWW.NAS-YA.COM

Project:	RK3528_H29K	
File:	05.RK3528 FLASH/SD Controller	
Date:	Thursday, November 14, 2024	Rev: <Revision>
Designer:	<designer>	Sheet: 6 of 25

# RK3528\_I (USB2.0 OTG/HOST)

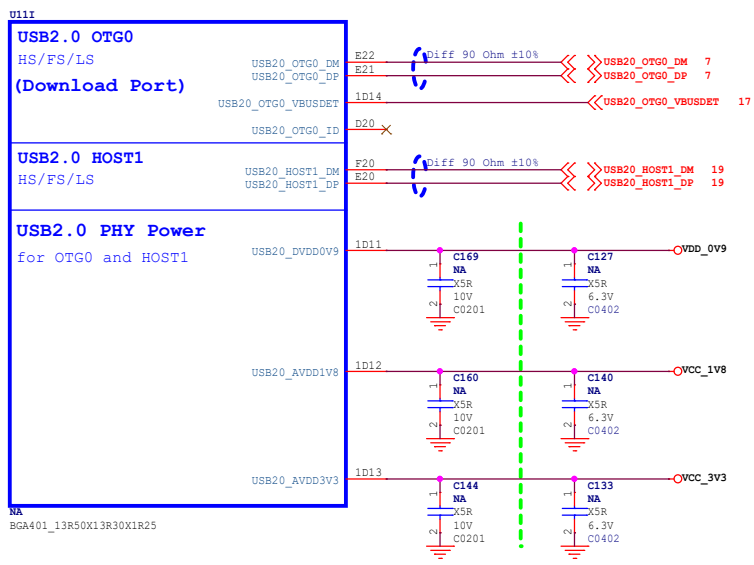

**Note:**  
Caps of between dashed green lines and U1000 should be placed under the U1000 package.  
Other caps should be placed close to the U1000 package

# RK3528\_J (PCIE2.0/U3 PHY)

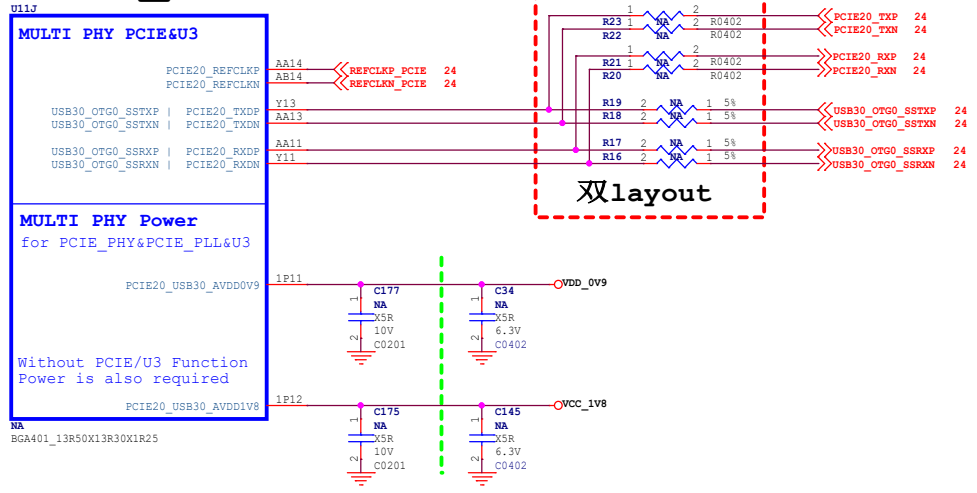

**Note:**  
Caps of between dashed green lines and U1000 should be placed under the U1000 package.  
Other caps should be placed close to the U1000 package

<b>WWW.NAS-YA.COM</b>				
Project:	RK3528_H29K	那是鸭!	Rev:	<Revision>
File:	06.RK3528 USB/PCIE Controll		Sheet:	7 of 25
Date:	Thursday, November 14, 2024	Designer:	<designer>	

# RK3528\_C (Saradc/OTP)

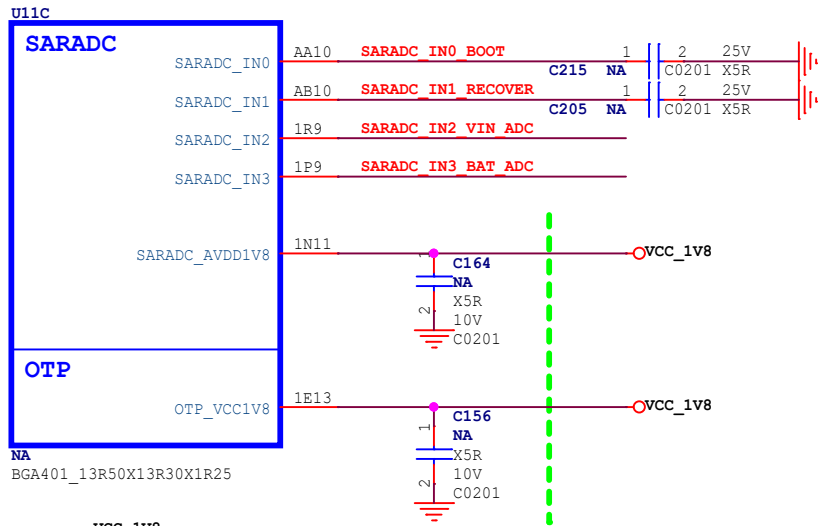

← SARADC\_IN0\_BOOT 7

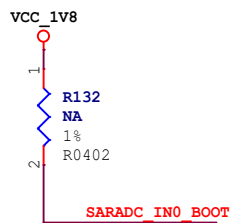
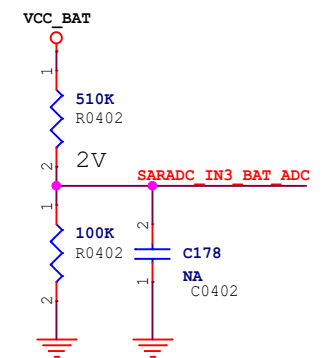
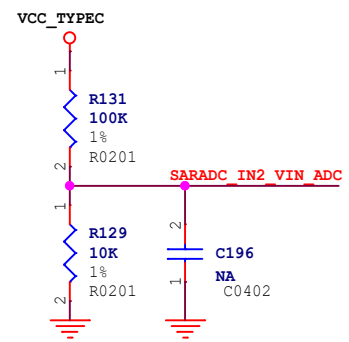
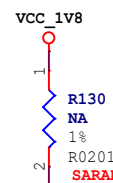

输入电压监测  
 输入电压=读数电压x11  
 如读数电压1.0V, 则电池对于1.0x11=11V

电池监测  
 电池电压=读数电压x6.1  
 如读数电压1.2V, 则电池对于1.2x6.1=7.32V

软件调试Note:

软件调试Note:

## TABLE

Item	Rup	Rdown	ADC	BOOT MODE
LEVEL1	DNP	100K	0	USB (Maskrom mode)
LEVEL2	100K	12K	114	
LEVEL3	100K	27K	228	FSPI--USB
LEVEL4	100K	51K	342	
LEVEL5	100K	82K	456	
LEVEL6	100K	120K	570	EMMC--USB
LEVEL7	100K	200K	683	EMMC--SD Card--USB
LEVEL8	100K	330K	796	SD Card--USB
LEVEL9	100K	820K	910	
LEVEL10	100K	DNP	1023	FSPI--EMMC--SD Card--USB

**WWW.NAS-YA.COM**

Project:	RK3528_H29K	👉 那是吗!
File:	07.RK3528 SARADC/OTP	
Date:	Thursday, November 14, 2024	Rev: <Revision>
Designer:	<designer>	Sheet: 8 of 25



# RK3528\_L (HDMI PHY)

U11L

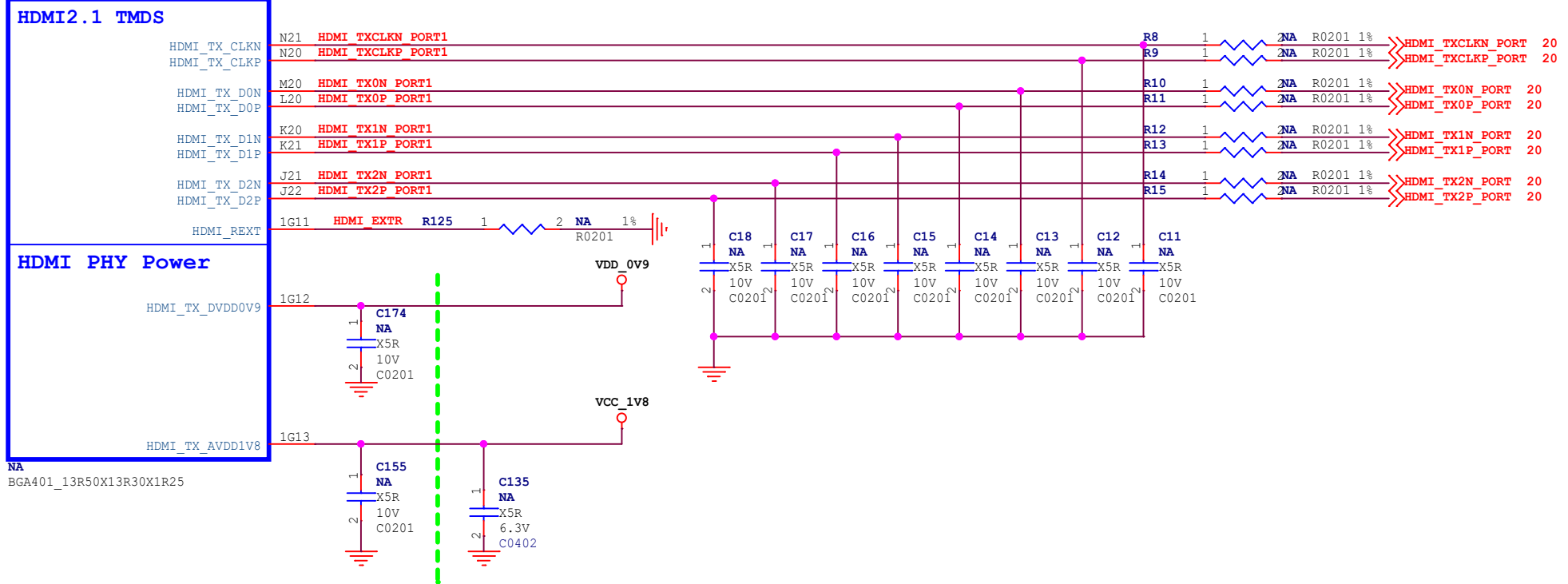

**Note:**

Caps of between dashed green lines and U1000 should be placed under the U1000 package.  
Other caps should be placed close to the U1000 package

**WWW.NAS-YA.COM**

<b>Project:</b>	RK3528_H29K	 <b>那是吗!</b>
<b>File:</b>	08.RK3528 HDMI Interface	
<b>Date:</b>	Thursday, November 14, 2024	<b>Rev:</b> <Revision>
<b>Designer:</b>	<designer>	<b>Sheet:</b> 9 of 25

# RK3528\_M (Acodect/VDAC)

## 软件调试Note:

低功耗，软件上可以关闭ACODEC

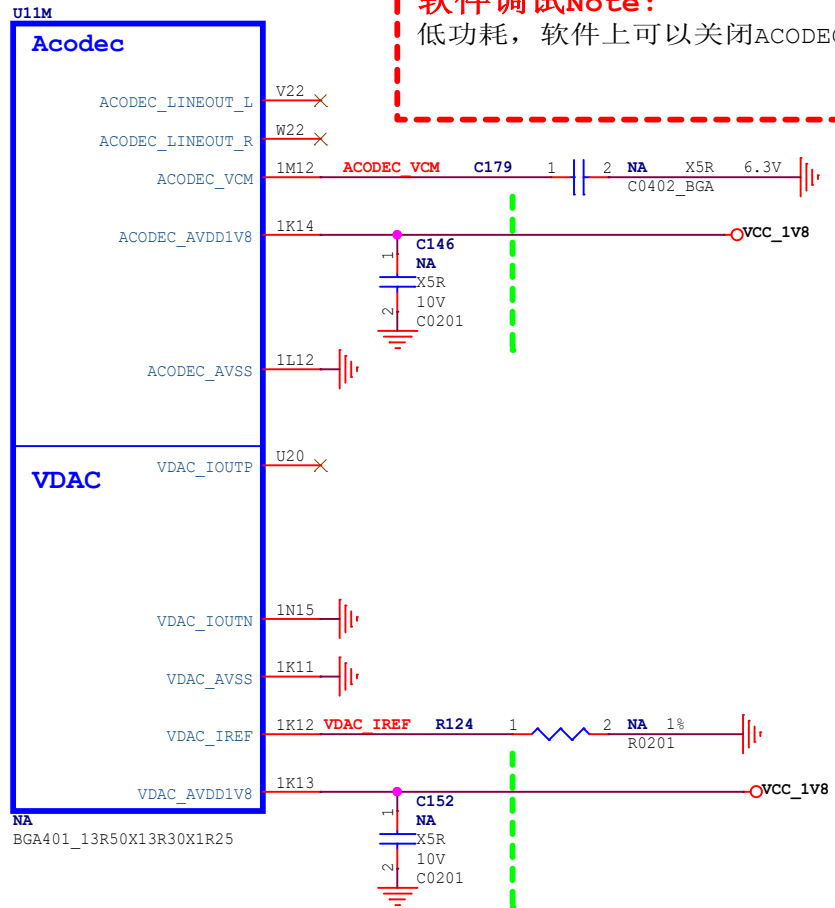

## Note:

Caps of between dashed green lines and U1000 should be placed under the U1000 package.  
Other caps should be placed close to the U1000 package

**WWW.NAS-YA.COM**

<b>Project:</b>	RK3528_H29K	🧸 那是鸭!
<b>File:</b>	09.RK3528 AV OUT	
<b>Date:</b>	Thursday, November 14, 2024	Rev: <Revision>
<b>Designer:</b>	<designer>	Sheet: 10 of 25

# RK3528\_K (Embed FEPHY)

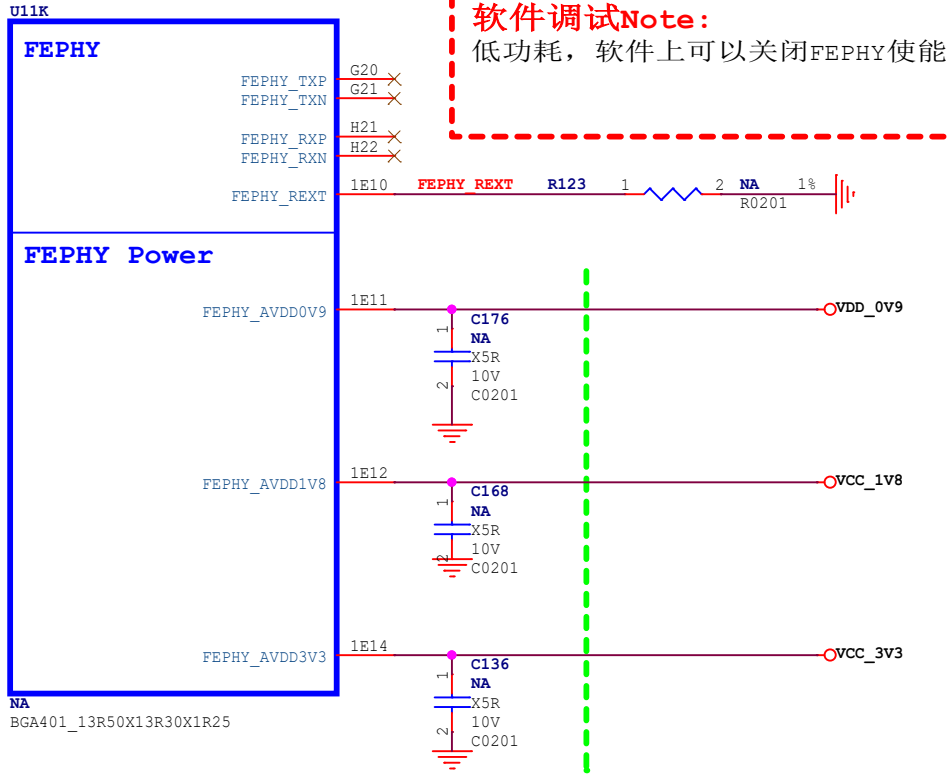

WWW.NAS-YA.COM

Project:	RK3528_H29K	 那是鸭!
File:	10.RK3528 Embed FEPHY	
Date:	Thursday, November 14, 2024	Rev: <Revision>
Designer:	<designer>	Sheet: 11 of 25

### RK3528\_D (VCCIO0 Domain)

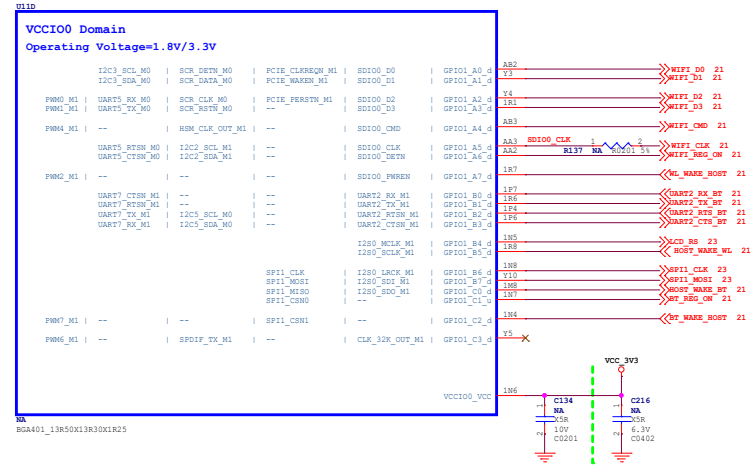

**软件调试Note:**  
H29k与H12c一模一样的，就是新增了5G模块和5g相关IO  
屏幕IO

**软件调试Note:**  
SPI彩色屏幕

**Note:**  
Caps of between dashed green lines and U1000 should be placed under the U1000 package. Other caps should be placed close to the U1000 package

### RK3528\_G (VCCIO3 Domain)

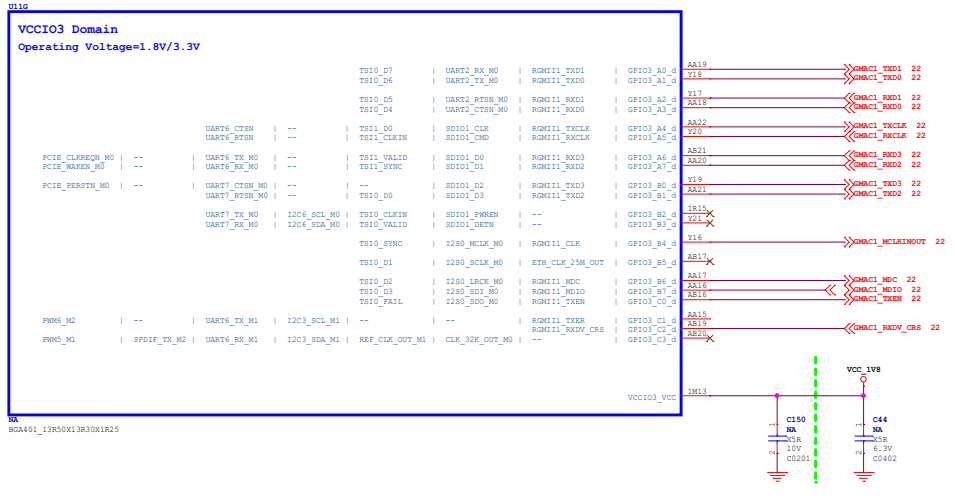

**Note:**  
Caps of between dashed green lines and U1000 should be placed under the U1000 package. Other caps should be placed close to the U1000 package

### RK3528\_H (VCCIO4 Domain)

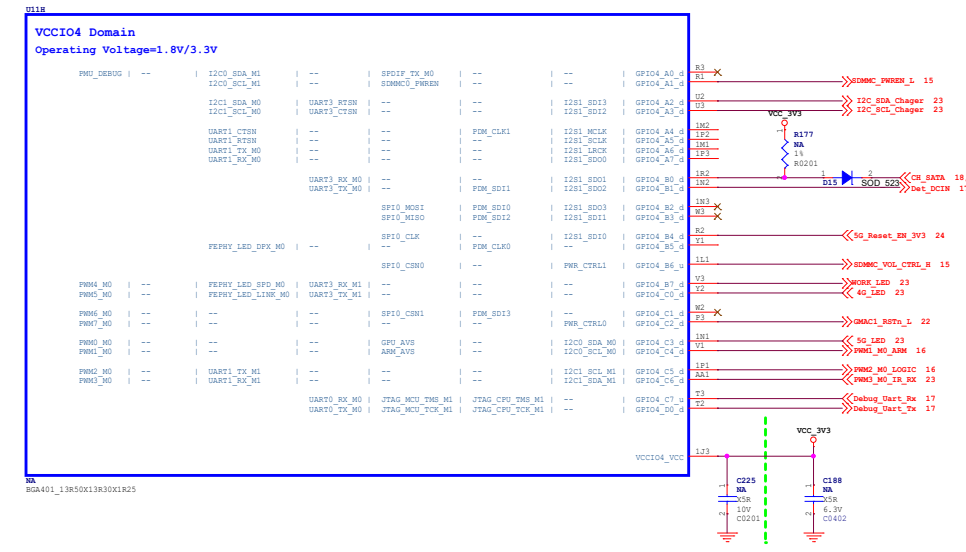

**软件调试Note:**  
CH SATA 电池充满电状态捕获，低电平为充电，高电平为充满或者关团  
DeT\_DCIN 监测TYPE-C有电源输入，高电平说明有输入，低电平说明无输入或者输入异常  
5G Reset\_EN\_V3V3 输出高店电平，5G模块复位引脚则为低  
GPIO4\_C0的4G LED 在安卓系统中代表网络连接  
GPIO4\_C3的5G LED 在CPE中代表5G网络

**Note:**  
Caps of between dashed green lines and U1000 should be placed under the U1000 package. Other caps should be placed close to the U1000 package

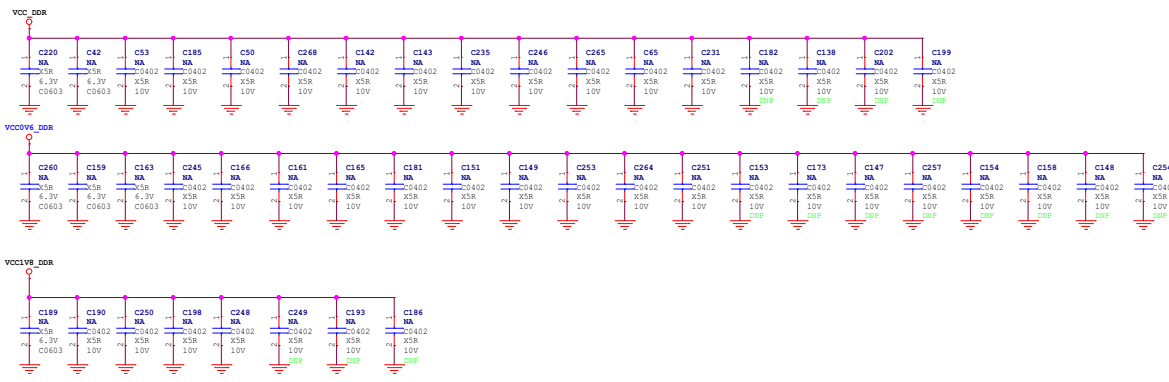
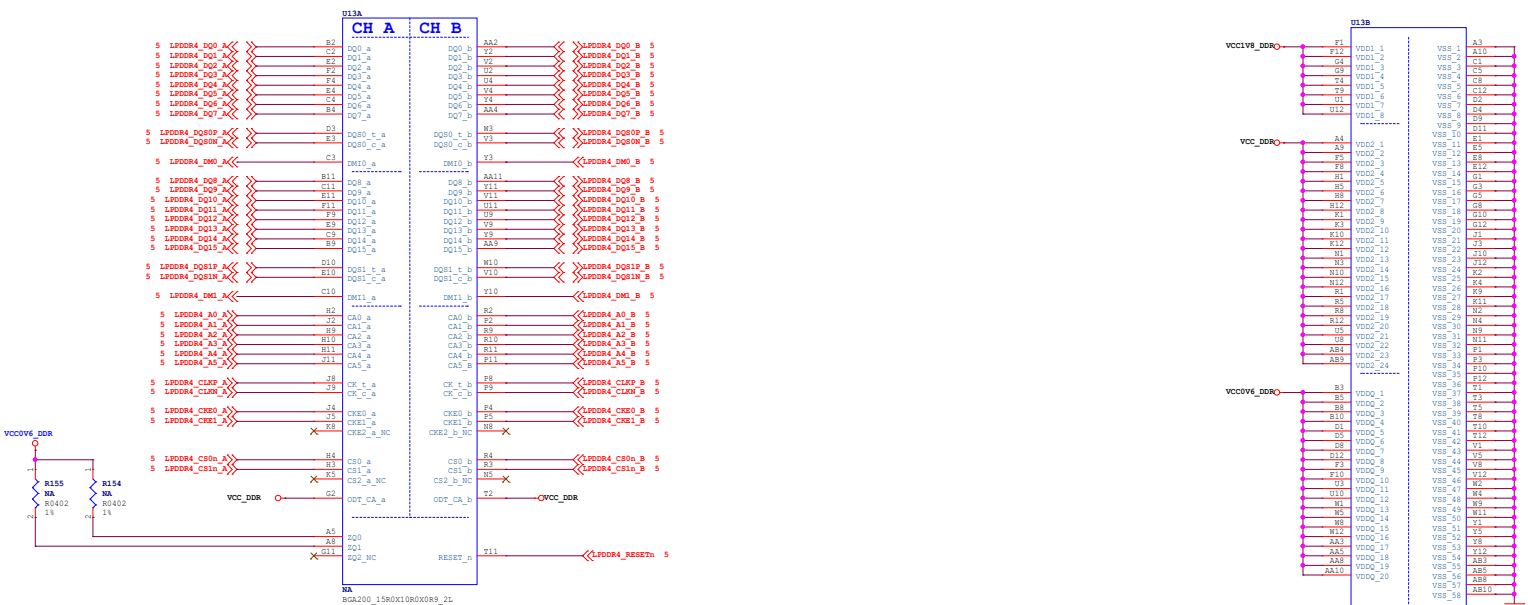

VCC0V6\_DDR

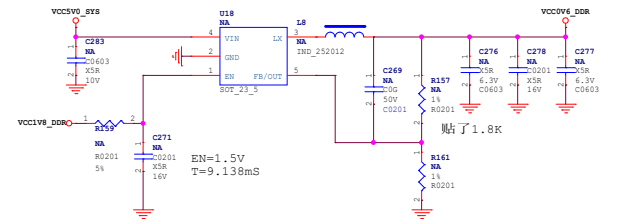

VCC1V8\_DDR

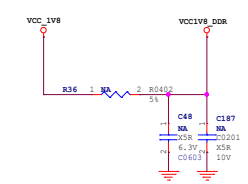

# EMMC

## FSPI

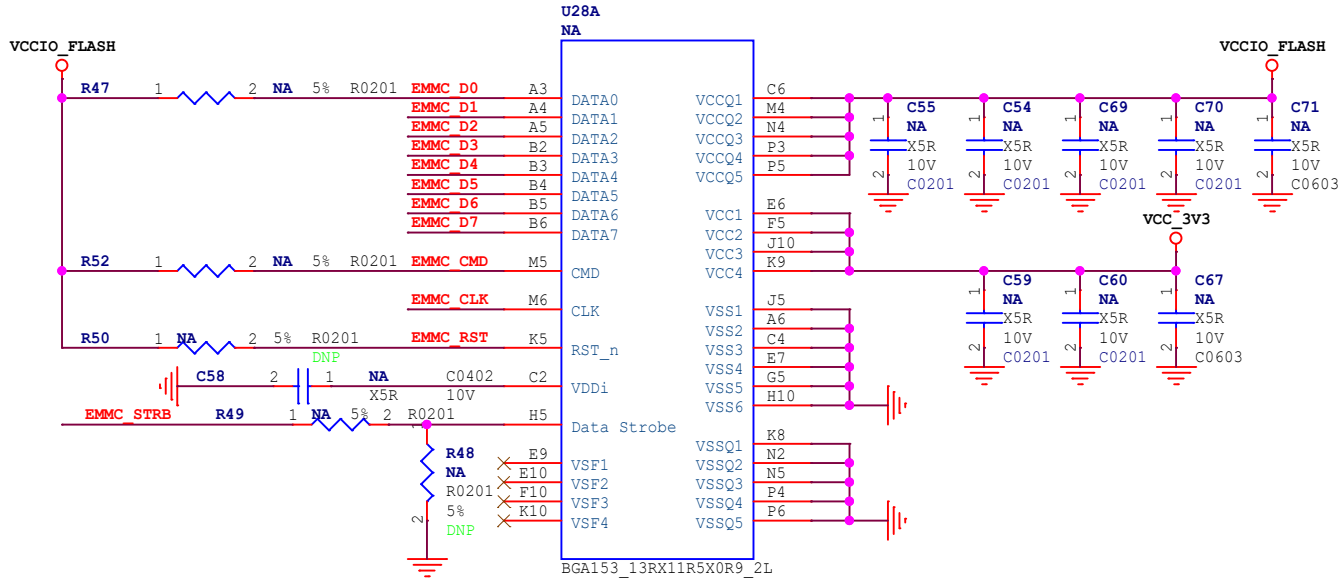
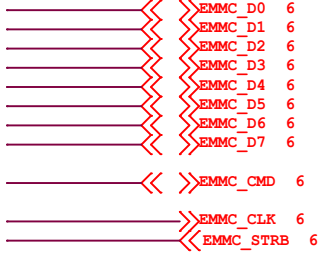

U28B		NA	
A2	NC2	REF11	NC196
A8	NC8	REF12	NC195
A9	NC9	REF13	NC194
A10	NC10	REF14	NC193
A11	NC11	REF15	NC191
A12	NC12	REF16	NC190
A13	NC13	REF17	NC184
A14	NC14	REF18	NC183
B1	NC15	REF19	NC182
B7	NC21	REF20	NC181
B8	NC22	REF21	NC180
B9	NC23	REF22	NC179
B10	NC24	REF23	NC178
B11	NC25	REF24	NC177
B12	NC26	REF25	NC176
B13	NC27	REF26	NC175
B14	NC28	REF27	NC174
C1	NC29	REF28	NC171
C3	NC31	REF29	NC169
C7	NC35		NC168
C8	NC36		NC167
C9	NC37		NC166
C10	NC38		NC165
C11	NC39		NC164
C12	NC40		NC163
C13	NC41		NC162
C14	NC42		NC161
D1	NC43		NC157
D2	NC44		NC156
D3	NC45		NC155
D4	NC46		NC154
D12	NC54		NC153
D13	NC55		NC152
D14	NC56		NC151
E1	NC57		NC148
E2	NC58		NC147
E3	NC59		NC146
E12	NC68		NC145
E13	NC69		NC144
E14	NC70		NC143
F1	NC71		NC142
F2	NC72		NC141
F3	NC73		NC140
F12	NC82		NC139
F13	NC83		NC138
F14	NC84		NC137
G1	NC85		NC136
G2	NC86		NC135
G12	NC96		NC134
G13	NC97		NC133
G14	NC98		NC132
			NC131
			NC130
			NC129
			NC128
			NC127
			NC126
			NC125
			NC124
			NC123
			NC122
			NC121
			NC120
			NC119
			NC118
			NC117
			NC116
			NC115
			NC114
			NC113
			NC112
			NC111
			NC110
			NC109
			NC108
			NC107
			NC106
			NC105
			NC104
			NC103
			NC102
			NC101
			NC100
			NC99
			NC98
			NC97
			NC96
			NC95
			NC94
			NC93
			NC92
			NC91
			NC90
			NC89
			NC88
			NC87
			NC86
			NC85
			NC84
			NC83
			NC82
			NC81
			NC80
			NC79
			NC78
			NC77
			NC76
			NC75
			NC74
			NC73
			NC72
			NC71
			NC70
			NC69
			NC68
			NC67
			NC66
			NC65
			NC64
			NC63
			NC62
			NC61
			NC60
			NC59
			NC58
			NC57
			NC56
			NC55
			NC54
			NC53
			NC52
			NC51
			NC50
			NC49
			NC48
			NC47
			NC46
			NC45
			NC44
			NC43
			NC42
			NC41
			NC40
			NC39
			NC38
			NC37
			NC36
			NC35
			NC34
			NC33
			NC32
			NC31
			NC30
			NC29
			NC28
			NC27
			NC26
			NC25
			NC24
			NC23
			NC22
			NC21
			NC20
			NC19
			NC18
			NC17
			NC16
			NC15
			NC14
			NC13
			NC12
			NC11
			NC10
			NC9
			NC8
			NC7
			NC6
			NC5
			NC4
			NC3
			NC2
			NC1
			NC0
			NC-1
			NC-2
			NC-3
			NC-4
			NC-5
			NC-6
			NC-7
			NC-8
			NC-9
			NC-10
			NC-11
			NC-12
			NC-13
			NC-14
			NC-15
			NC-16
			NC-17
			NC-18
			NC-19
			NC-20
			NC-21
			NC-22
			NC-23
			NC-24
			NC-25
			NC-26
			NC-27
			NC-28
			NC-29
			NC-30
			NC-31
			NC-32
			NC-33
			NC-34
			NC-35
			NC-36
			NC-37
			NC-38
			NC-39
			NC-40
			NC-41
			NC-42
			NC-43
			NC-44
			NC-45
			NC-46
			NC-47
			NC-48
			NC-49
			NC-50
			NC-51
			NC-52
			NC-53
			NC-54
			NC-55
			NC-56
			NC-57
			NC-58
			NC-59
			NC-60
			NC-61
			NC-62
			NC-63
			NC-64
			NC-65
			NC-66
			NC-67
			NC-68
			NC-69
			NC-70
			NC-71
			NC-72
			NC-73
			NC-74
			NC-75
			NC-76
			NC-77
			NC-78
			NC-79
			NC-80
			NC-81
			NC-82
			NC-83
			NC-84
			NC-85
			NC-86
			NC-87
			NC-88
			NC-89
			NC-90
			NC-91
			NC-92
			NC-93
			NC-94
			NC-95
			NC-96
			NC-97
			NC-98
			NC-99

BGA153\_13RX11R5X0R9\_2L

WWW.NAS-YA.COM

Project:	RK3528_H29K		
File:	13.Flash-eMMC		
Date:	Thursday, November 14, 2024	Rev:	<Revision>
Designer:	<designer>	Sheet:	14 of 25

# TF Card

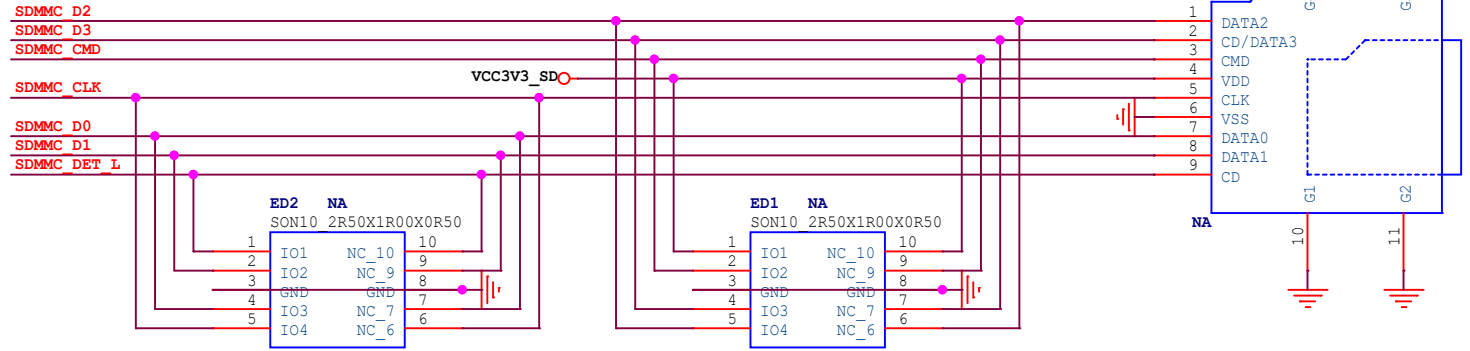
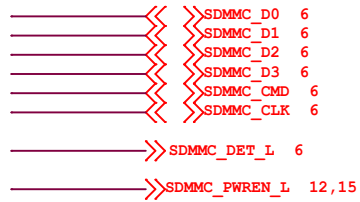

# VCCIO\_SD

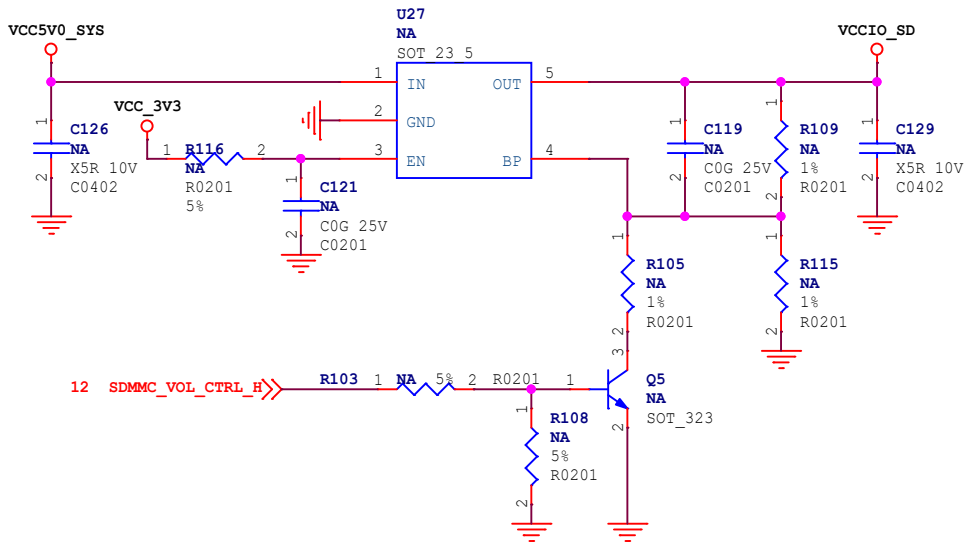

# VCC3V3\_SD

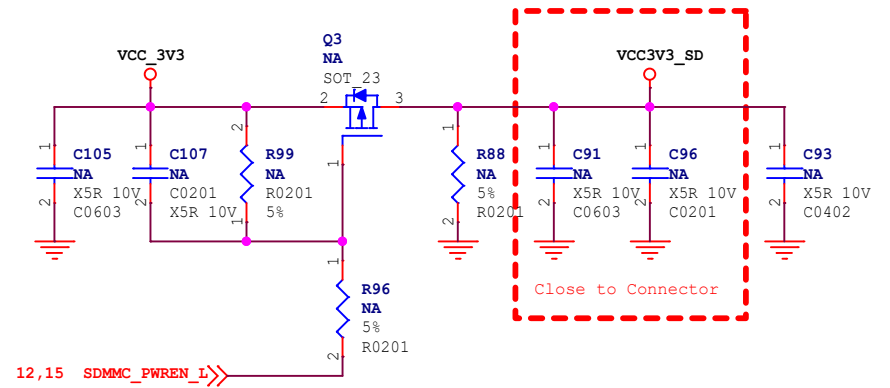

SDMMC\_PWREN=L VCC\_SD=3.3V(Default)  
SDMMC\_PWREN=H VCC\_SD=0V

SDIO2.0 SDMMC0\_VOL\_CTRL=H VCCIO\_SD=3.34V(Default)  
SDIO3.0 SDMMC0\_VOL\_CTRL=L VCCIO\_SD=1.816V

[WWW.NAS-YA.COM](http://WWW.NAS-YA.COM)

Project:	RK3528_H29K	
File:	14.Flash-Micro-SD Card	
Date:	Thursday, November 14, 2024	Rev: <Revision>
Designer:	<designer>	Sheet: 15 of 25

### VCC5V0\_SYS-->VDD\_LOGIC

#### Step 1

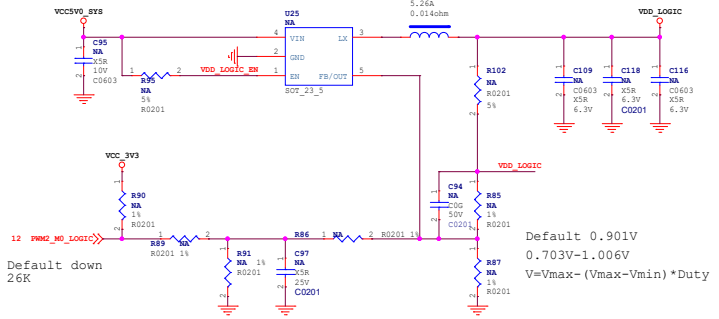

### VCC5V0\_SYS-->VDD\_ARM

#### Step 1

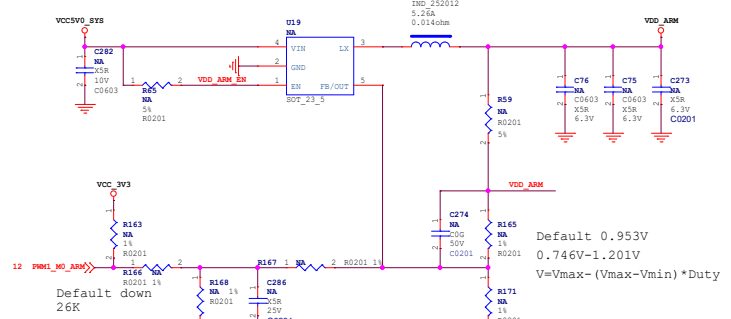

### VCC5V0\_SYS-->VDD\_0V9

#### Step 1

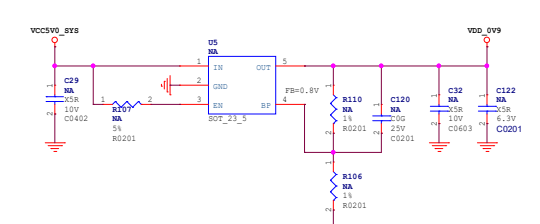

### VCC\_3V3->VCC\_1V8(LDO)

#### Step 2

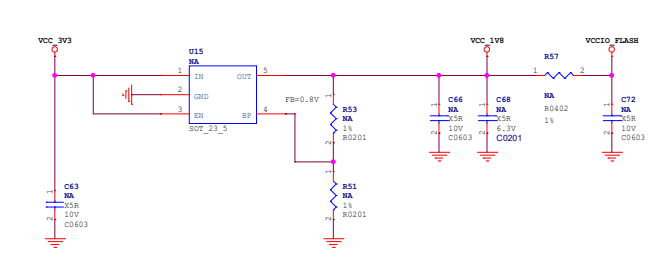

### VCC5V0\_SYS-->VCC\_DDR

#### Step 2

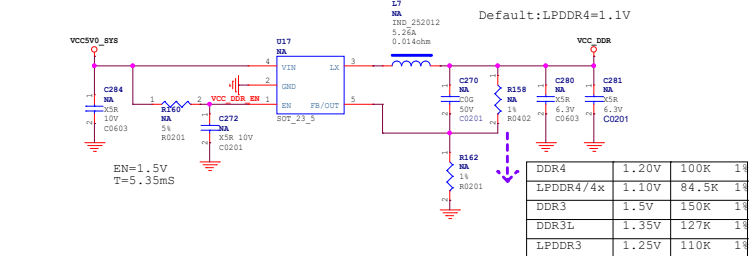

### VCC5V0\_SYS-->VCC\_3V3

#### Step 2

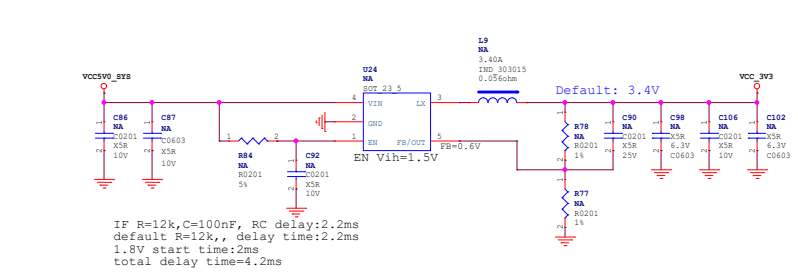



## UART Debug+OTG+PD

调试串口信号在**type-c**里，需使用鸭子的板子

[WWW.NAS-YA.COM](http://WWW.NAS-YA.COM)

Project:	RK3528_H29K	 那是鸭!
File:	16.Power-DCIN	
Date:	Thursday, November 14, 2024	Rev: <Revision>
Designer:	<designer>	Sheet: 17 of 25

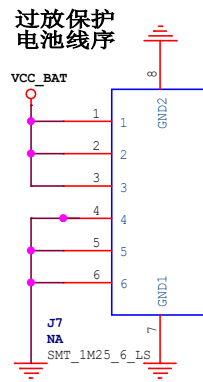

**WWW.NAS-YA.COM**

Project:	RK3528_H29K	🤖 那是鸭!
File:	17.Power_Charge	
Date:	Thursday, November 14, 2024	Rev: <Revision>
Designer:	<designer>	Sheet: 18 of 25

### USB2.0 HOST1

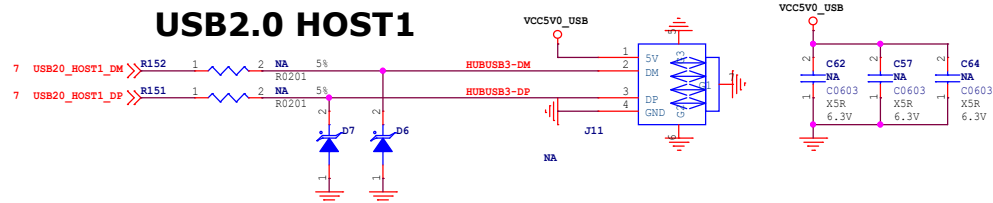

### USB输出放电能力 5V 500mA

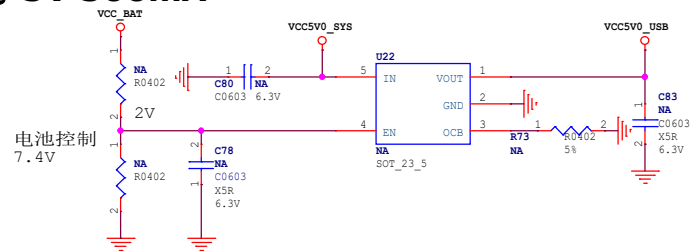

WWW.NAS-YA.COM

Project:	RK3528_H29K		
File:	18.USB_A		
Date:	Thursday, November 14, 2024		
Designer:	<designer>		
Rev:	<Revision>	Sheet:	19 of 25

HDMI\_TX2P\_PORT >>> HDMI\_TX2P\_PORT 9  
 HDMI\_TX2N\_PORT >>> HDMI\_TX2N\_PORT 9  
  
 HDMI\_TX1P\_PORT >>> HDMI\_TX1P\_PORT 9  
 HDMI\_TX1N\_PORT >>> HDMI\_TX1N\_PORT 9  
  
 HDMI\_TX0P\_PORT >>> HDMI\_TX0P\_PORT 9  
 HDMI\_TX0N\_PORT >>> HDMI\_TX0N\_PORT 9  
  
 HDMI\_TXCLKP\_PORT >>> HDMI\_TXCLKP\_PORT 9  
 HDMI\_TXCLKN\_PORT >>> HDMI\_TXCLKN\_PORT 9  
  
 HDMITX\_SCL >>> HDMITX\_SCL 4  
 HDMITX\_SDA >>> HDMITX\_SDA 4  
 HDMITX\_CEC >>> HDMITX\_CEC 4  
 HDMI\_TX\_HPDIN >>> HDMI\_TX\_HPDIN 4

### HDMI TX DDC

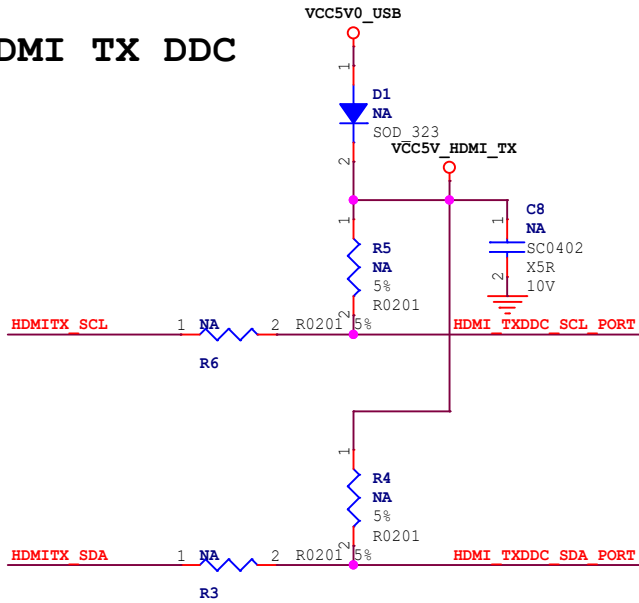

### HDMI TX CEC



### HDMI TX HPD

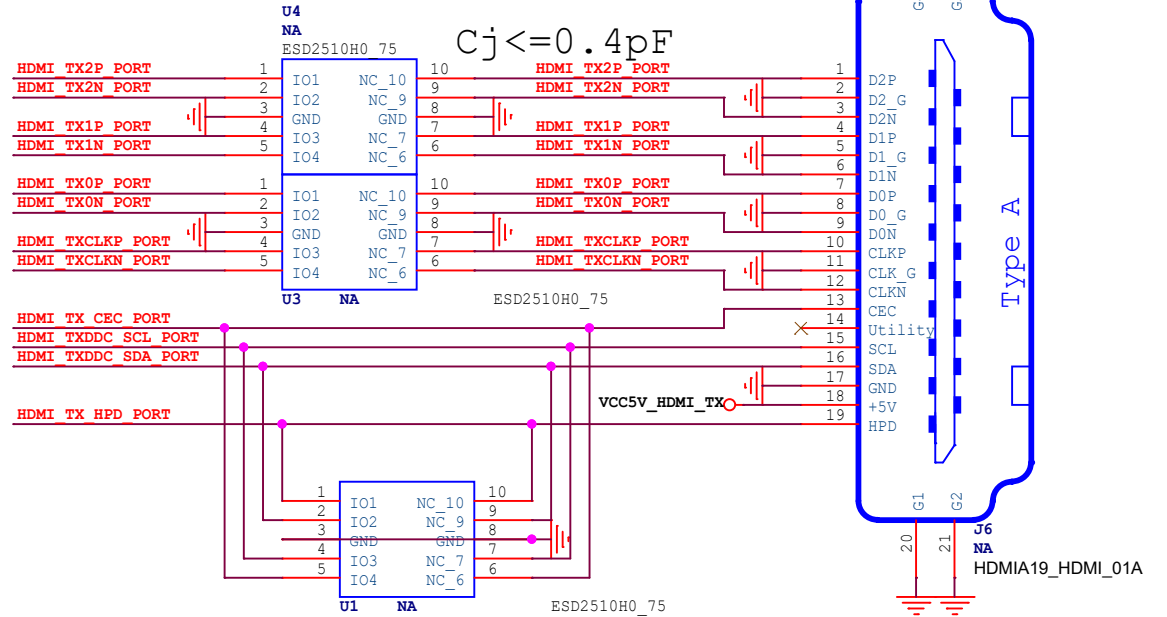
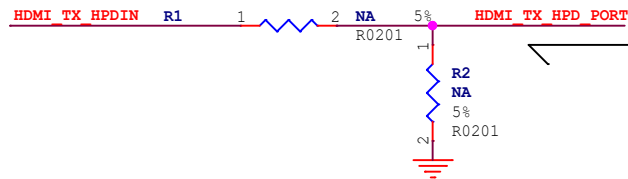

[WWW.NAS-YA.COM](http://WWW.NAS-YA.COM)

Project:	RK3528_H29K	那是吗!
File:	19.VO-HDMI2.0 TX	
Date:	Thursday, November 14, 2024	Rev: <Revision>
Designer:	<designer>	Sheet: 20 of 25

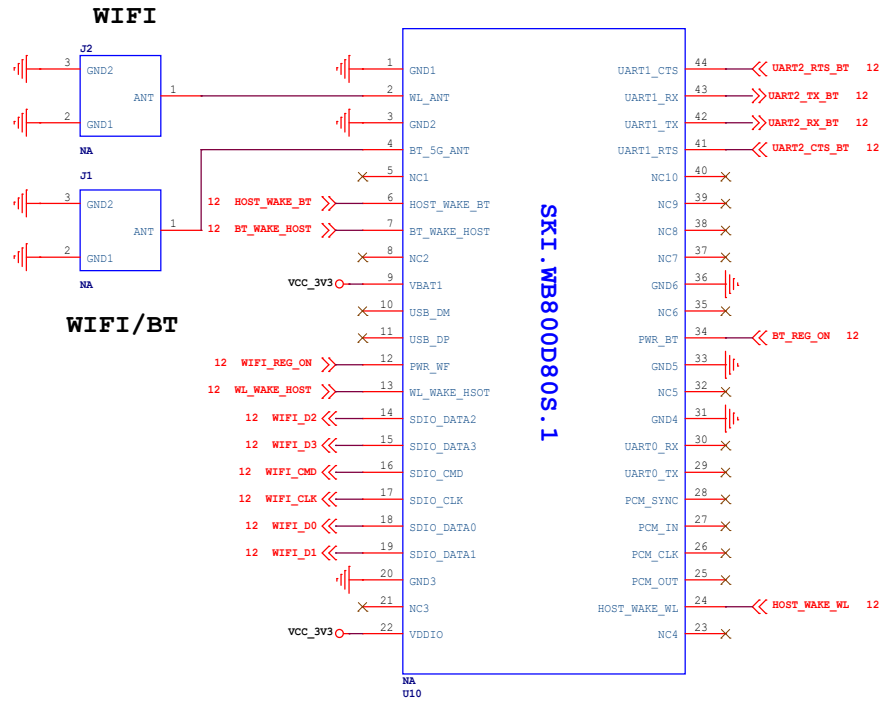

# 千兆以太网

[WWW.NAS-YA.COM](http://WWW.NAS-YA.COM)

Project:	RK3628_H29K	 那是吗!
File:	21.Ethernet-GEPHY_ROMII	
Date:	Thursday, November 14, 2024	Rev: <Revision>
Designer:	<designer>	Sheet: 22 of 25

# 红外接收头

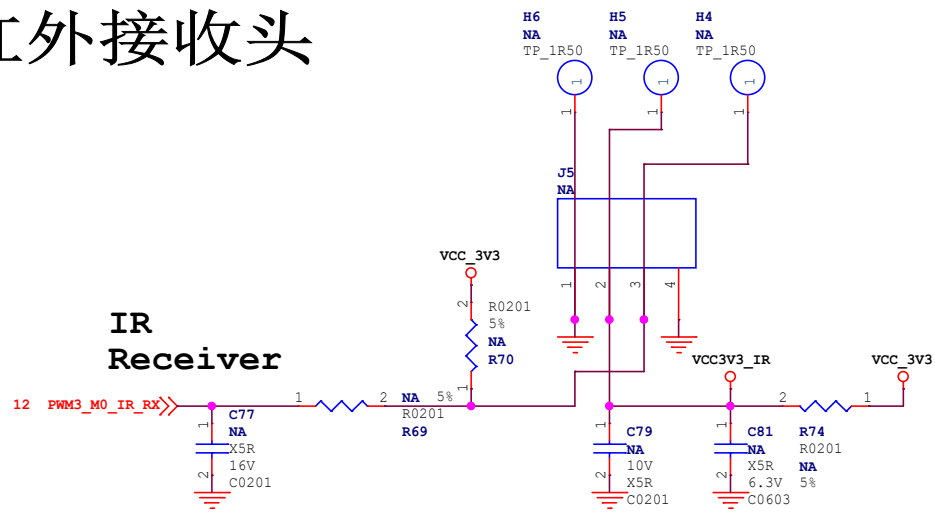

# 屏幕

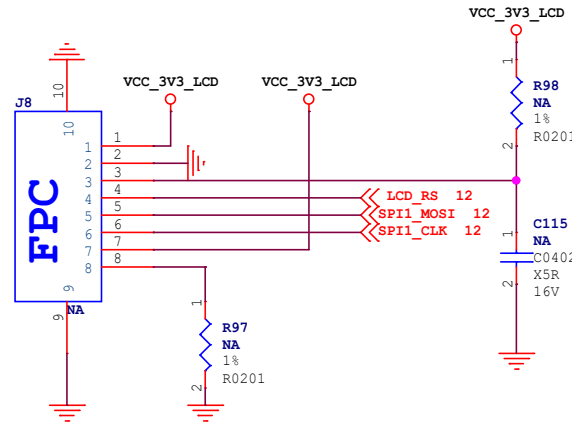

# 增加背光控制

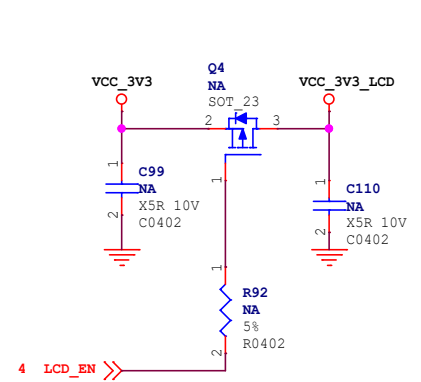

# 灯位置看位号图和产品介绍

1号灯

2号灯

3号灯

4号灯

5号灯

6号灯

4G灯

5G灯

网口

工作灯

放电灯

充电灯

白色灯

红色灯

蓝灯

黄灯

绿翠绿色

黄绿色

电源灯

红色灯

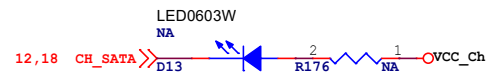
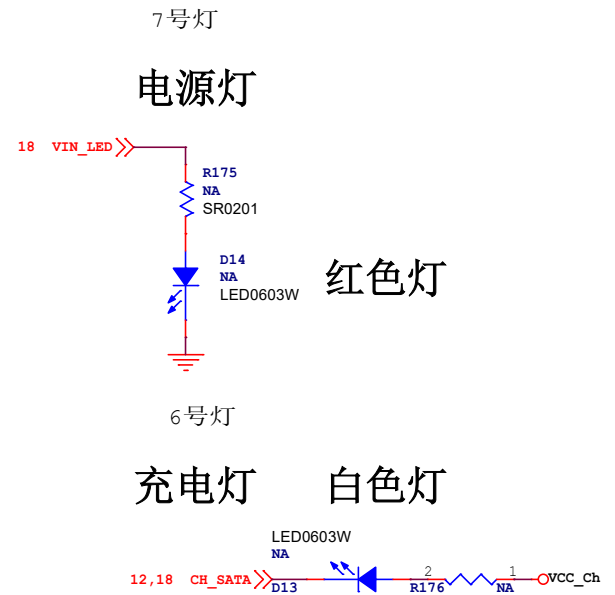
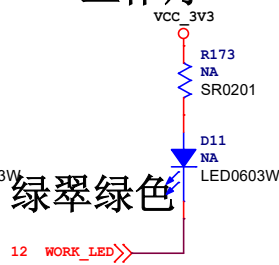
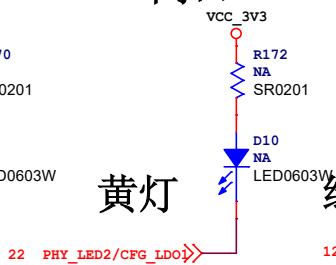
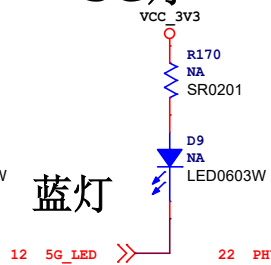
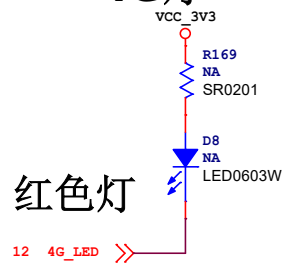

WWW.NAS-YA.COM

Project:	RK3528_H29K	🐼 那是鸭!
File:	22.Key/HW ID/LED	
Date:	Thursday, November 14, 2024	Rev: <Revision>
Designer:	<designer>	Sheet: 23 of 25

# 5G模块

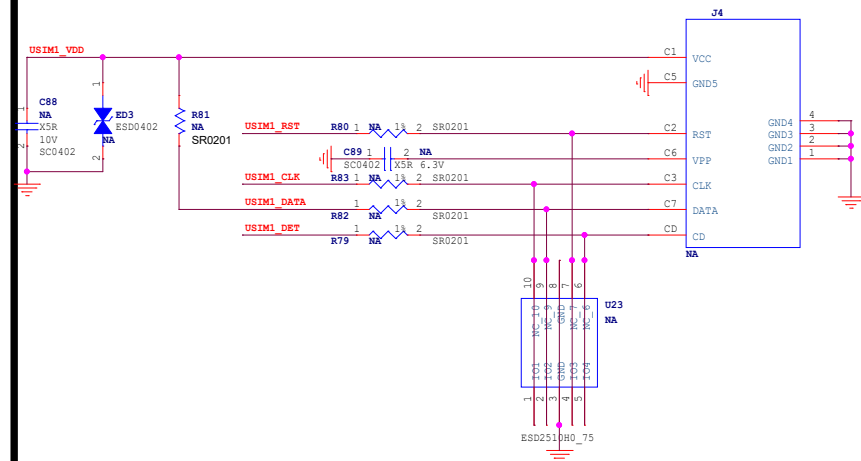
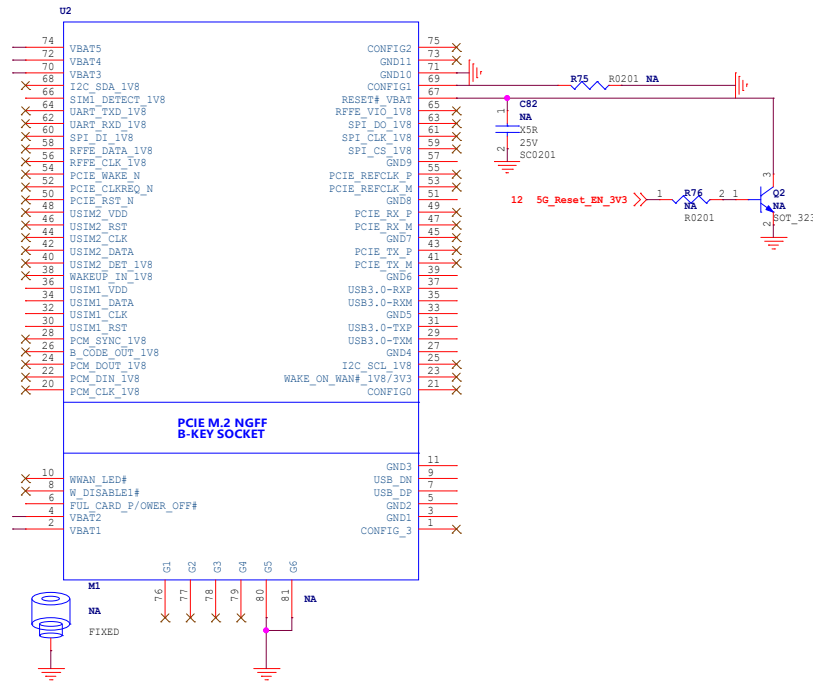

<b>WWW.NAS-YA.COM</b>			
Project:	RK3528_H28K	👉 那是吗!	
File:	23.4G/5G-MODULE		
Date:	Thursday, November 14, 2024	Rev:	<Revision>
Designer:	<designer>	Sheet:	24 of 25



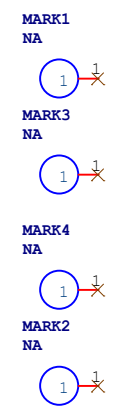
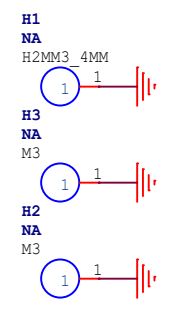
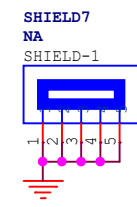
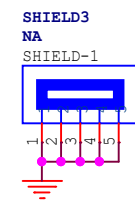
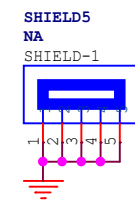
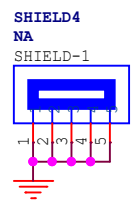
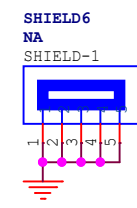
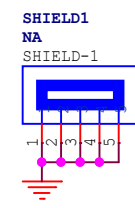
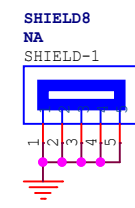
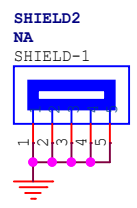

<b>WWW.NAS-YA.COM</b>			
<b>Project:</b>	RK3528_H29K		
<b>File:</b>	24.Mark/Hole		
<b>Date:</b>	Thursday, November 14, 2024	<b>Rev:</b>	<Revision>
<b>Designer:</b>	<designer>	<b>Sheet:</b>	25 of 25